

# **EP203 AUTOMATIC EXTINGUISHER PANEL**

## **Installation and Maintenance Manual**

Approved Document No. DFU0002032 Rev 8 26/08/22



## **CONTENTS**

<b>IMPORTANT NOTES</b> .....	<b>4</b>
<b>BASIC OVERVIEW AND KEY FEATURES</b> .....	<b>6</b>
<b>INSTALLATION AND WIRING</b> .....	<b>9</b>
The EP203 Panel Enclosure .....	9
Removing the Lid and Base PCBs.....	9
<b>FIRST FIX</b> .....	<b>10</b>
Cable Types and Limitations.....	10
Planning the Cable Entry and Distribution within the EP203 Panel .....	10
Siting and Mounting the EP203 Panel .....	11
Mains Wiring .....	11
Detector Circuit Wiring .....	12
Sounder Circuit Wiring .....	12
Monitored Input Wiring .....	13
Auxiliary Output Wiring.....	13
Remote Inputs & Aux Output Wiring .....	14
Extinguisher Output Wiring .....	15
Connection to RSUs and ESUs .....	17
<b>SECOND FIX</b> .....	<b>18</b>
Connecting the EP203 Panel.....	18
Installing the Power Supply PCB and Output Expansion Relay Board .....	18
Connecting the Mains Supply .....	18
Connecting the Standby Batteries.....	19
Installing the Main Control PCB .....	20
Connecting Circuits to the Main Control PCB .....	20
<b>PROGRAMMING THE EP203 PANEL</b> .....	<b>21</b>
General User Controls (Access Level 1).....	21
Authorised User Controls (Access Level 2) .....	21
Engineer Controls (Access Level 3).....	22
Accessing and using the Engineer Controls .....	22
<b>ACCESS LEVEL 3 MENUS</b> .....	<b>23</b>
Overview .....	23

## EP203 AUTOMATIC EXTINGUISHER PANEL

---

Display Faults.....	24
Display Dis/mnt .....	24
Zones in Test .....	24
Display RSUs .....	24
Disablements .....	25
Commissioning.....	27
Engineering .....	31
<b>FAULT DIAGNOSIS.....</b>	<b>34</b>
Overview .....	34
Detection Zone Faults.....	34
Sounder Faults.....	35
Power Supply Faults .....	35
System Faults .....	38
<b>GENERAL MAINTENANCE.....</b>	<b>39</b>
<b>APPENDICES .....</b>	<b>40</b>
APPENDIX 1 – Standby Battery Calculation Guide .....	40
APPENDIX 2 – Extinguisher Control Panel Wiring Diagram.....	41
APPENDIX 3 – Extinguishing Operation Flowchart .....	41
APPENDIX 4 – Technical Specification .....	42

## FIGURES

Figure 1 : Overview of Access Level Menus.....	7
Figure 2 : Location of Enclosure Mounting Holes and Knockouts.....	10
Figure 3 : Mains Wiring.....	11
Figure 4 : Typical Detector Circuit Wiring.....	12
Figure 5 : Typical Sounder Circuit Wiring.....	12
Figure 6 : Typical Monitored Input Wiring.....	13
Figure 7 : Typical Remote Inputs & Aux Output Wiring .....	14
Figure 8 : Typical Solenoid Circuit Wiring .....	15
Figure 9 : Typical Igniting Actuator Circuit Wiring.....	16
Figure 10 : Typical RSU Circuit Wiring .....	17
Figure 11 : Typical ESU Circuit Wiring.....	17
Figure 12 : Power Supply PCB Layout and Connection Details.....	19
Figure 13 : Battery Location and Connection Details .....	19

E&OE. No responsibility can be accepted by the manufacturer or distributors of this range of extinguisher panels for any misinterpretation of an instruction or guidance note or for the compliance of the system as a whole. The manufacturer's policy is one of continuous improvement and we reserve the right to make changes to product specifications at our discretion and without prior notice.



Manufacturer: Comptonics Limited (C-TEC), Challenge Way, Martland Park, Wigan, Lancashire WN5 0LD [www.c-tec.com](http://www.c-tec.com)

## EP203 AUTOMATIC EXTINGUISHER PANEL



Model: EP203

2831-CPR-F4090

0832-UKCA-CPR-F1111

### IMPORTANT NOTES



**THIS EQUIPMENT MUST ONLY BE INSTALLED AND MAINTAINED BY A SUITABLY SKILLED AND TECHNICALLY COMPETENT PERSON.**

#### Equipment Guarantee

This equipment is not guaranteed unless the complete system is installed and commissioned in accordance with the laid down national standards by an approved and competent person, or organisation.



This product has been manufactured in conformance with the requirements of all applicable EU Council Directives and the Construction Products Regulation (EU) No. 305/2011.

#### Items supplied with the EP203 panel:

- Installation and Maintenance Manual – Document No. DFU0002032 (this manual)  
**Note:** This manual MUST NOT be left accessible to the general user.
- User Manual/Log Book – Document No. DFU0002031
- Shortform Installation Instructions – Document No. DFU0002033
- Accessory pack containing the following items:
  - 1 x Allen key (for unfastening/securing the panel lid)
  - 12 x 6K8, 0.25W (end-of-line resistors)
  - 1 x T 2A H 230 V, 20 mm ceramic (spare mains supply fuse F1)
  - 1 x 7.5A MINI® automotive blade fuse (spare battery fuse F2)
  - 1 x key set (pair)
  - 1 x set of battery connection leads (red lead, black lead, green jump lead)

#### Module Reference/Description

The EP203 extinguisher release system is compliant with EN12094-1, EN54-2 & EN54-4 and comprises the following discrete modules:

SPF0000203	Main Extinguisher Control Board
SPF0000212	EP212 External Relay Interface board
SPF0361021	Power Supply Unit (PSU)
SPF0000214	EP214 Terminator Unit

Optional units available are:

EP210F	Remote Status Unit (flush mount)
EP210S	Remote Status Unit (surface mount)
EP211	Economy Status Unit
EP215	Emergency Hold/Abort button

### System Design

Fire alarm system and extinguisher system design are beyond the scope of this document.

A basic understanding of general system components and their use is assumed.

To ensure a reliable system and limit the consequences of faults, we strongly recommend that a suitably qualified and competent person is consulted in connection with the design of the fire alarm and extinguisher system and that the system is commissioned and maintained to local design and installation regulations. The fire officer concerned with the property should be contacted at an early stage in case he has any special requirements.

The EP203 Automatic Extinguisher Panel (hereafter called the EP203 panel) is compliant with the following European standards:

- EN 12094-1 – Fixed firefighting systems – Components for gas extinguishing systems - Part 1: Requirements and test methods for electrical automatic control and delay devices
- EN 54-2 and EN 54-4 – Fire Detection and Fire Alarm Systems – Control and Indicating Equipment (EN 54-2); Power Supply Equipment (EN 54-4).
- EN 12094-1 Section 4.17 ‘Delay of extinguishing signal (option with requirements)’ delay time from 0 to 60 seconds.
- EN 12094-1 Section 4.18 ‘Signal representing the flow of extinguishing agent (option with requirements)’ to indicate the flow of the extinguishing agent.
- EN 12094-1 Section 4.19 ‘Monitoring of the status of components (option with requirements)’ by way of a low pressure switch input.
- EN 12094-1 Section 4.20. ‘Emergency hold device (option with requirements)’ to enable the extinguishant delay time to be extended.
- EN 12094-1 Section 4.21 ‘Control of flooding time (option with requirements)’ to deactivate the releasing output after a set time period.
- EN 12094-1 Section 4.23 ‘Manual only mode (option with requirements)’ to disable the release of extinguishant via automatic detection devices.
- EN 12094-1 Section 4.26 ‘Triggering of equipment outside the system (option with requirements)’ by way of first and second stage contacts, etc.
- EN 12094-1 Section 4.27 ‘Emergency abort device (option with requirements)’ to inhibit the extinguishing signal until the emergency abort device has been deactivated.
- EN 12094-1 Section 4.30 ‘Activation of alarm devices with different signals (option with requirements)’ to indicate pre-discharge and released warnings using different sounds.

In addition to the basic requirements of EN 54-2, the EP203 panel meets the following criteria:

- EN 54-2 Section 7.8 ‘Fire alarm devices (option with requirements)’ to enable an audible warning to be sounded throughout the premises upon the detection of a fire condition or the operation of a manual call point.
- EN 54-2 Section 7.11. ‘Delay of the actioning (option with requirements)’ of fire alarm devices (sounders) so that an alarm may be verified before a premises is evacuated.
- EN 54-2 Section 7.13. ‘Alarm counter (option with requirements)’ to record the number of instances the panel enters the fire alarm condition.
- EN 54-2 Section 10 ‘Test condition (option with requirements)’ to allow the automatic resetting of zones in alarm for testing purposes.

In addition to the requirements of EN 54-2, the EP203 panel has volt-free relay contacts for fire and local fire that operate upon a fire condition. These are to be used for local control and signaling.

## BASIC OVERVIEW AND KEY FEATURES

The EP203 panel acts as both a conventional fire alarm panel and an automatic extinguisher control panel. The panel is easy to install, programmable and incorporates a user-friendly LCD interface.

The EP203 panel's features include the following:

- Abort and hold functions for cancelling, or delaying the extinguishant release sequence
- Very low quiescent current drain on mains fail (40mA approx.)
- 128 x 64 pixel graphic LCD unit with two-colour backlight, provides a user-friendly interface for presentation of information, interrogation of data and programmable functions
- Front-panel mounted extinguisher release button and two keyswitches; one to enter access mode and one to toggle between automatic/manual modes of operation
- Powerful 3A, EN 54-4 compliant, switch mode PSU rated @230Vac, 50/60Hz that combines the functions of a power supply unit, battery charging unit and battery monitoring unit
- Three-zone conventional detector circuits, line monitored for open and short circuit faults. Any zone combination can be programmed to activate an alarm and initiate the extinguishant release sequence
- Three conventional alarm sounder circuits (two x 1st stage 1A & 1B, one x 2nd stage), line monitored for open and short circuit faults
- Monitored inputs for:  
Manual Release, Flow Switch, Low Pressure, Mode, Hold and Abort
- Auxiliary outputs for:  
Fire, Local Fire, Extract, 1st Stage, 2nd Stage, Fault
- Extinguishant output supports up to 2 x solenoids, or multiple 'Metrons™'
- Adjustable extinguishant release time delay, duration and flooding time
- Time-stamped event log
- Alarm counter to record the number of times the panel has been in an alarm state
- Output Expansion Relay Board providing additional volt-free relay outputs for: Reset, Mode, Discharged, Hold and Abort. **Note:** This board is optional if EN 12094-1 compliance is not required.
- Connections for up to eight Remote Status Units (RSU) which provide remote indication of system status on an LCD unit with mode select and manual extinguishant release
- Connections for up to eight Economy Status Units (ESU) to provide remote indication of system status with mode select.

## EP203 AUTOMATIC EXTINGUISHER PANEL

- Pushbutton and keyswitch entry to three access levels. See Figure 1, below.

Access Level 1 (AL1) is for general users

Access Level 2 (AL2) is for authorised users

Access Level 3 (AL3) is for engineers.

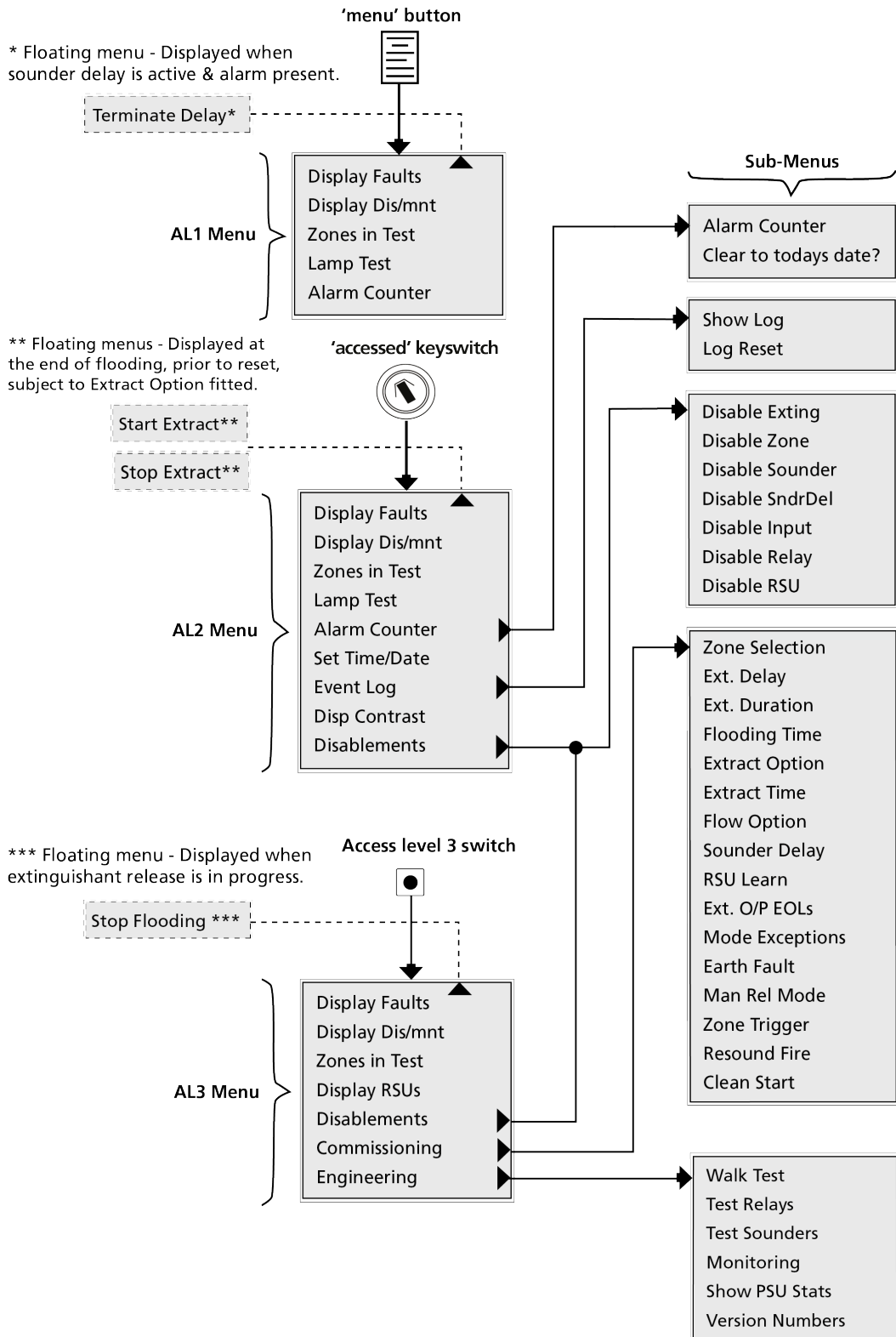

Figure 1 : Overview of Access Level Menus

## EP203 AUTOMATIC EXTINGUISHER PANEL

- System expansion connections for the following add-ons:

### Output Expansion Relay Board - Part No. EP212 (required for EN 12094-1 compliance)

- One Output Expansion Relay Board can be connected.
- Provides up to five volt-free relay outputs (Reset, Mode, Discharged, Hold, Abort).
- Mounted inside the EP203 panel.
- Instruction document no. DFU0000212.

### Remote Status Unit (RSU) - Part No. EP210S/EP210F

- Up to eight RSUs can be connected.  
Total wiring length < 30 metres.
- Provides remote indication of system status.
- Flush-mounted (EP210F), or surface-mounted (EP210S).
- Mode (Manual, or Manual & Automatic).
- Manual release of extinguishant.
- 128 x 64 pixel graphic LCD unit with two-colour backlight.
- Three monitored inputs (Abort, Hold and Mode).
- 2-wire RS485 + 2-wire power (24V).
- Instruction document no. DFU0000210.

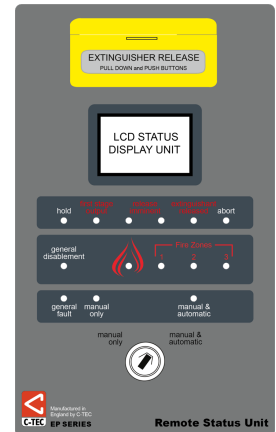

### Economy Status Unit (ESU) - Part No. EP211

- Up to eight ESUs can be connected.  
Total wiring length < 30 metres.
- Provides remote indication of extinguishant “release imminent”.
- Single-gang mounting arrangement.
- Mode (Manual, or Manual & Automatic).
- 2-wire power (24V) + 2-wire mode select
- 6K8 EOL resistor fitted in last EP215 allows wiring to be monitored for open and short-circuit faults
- Instruction document no. DFU0000211.

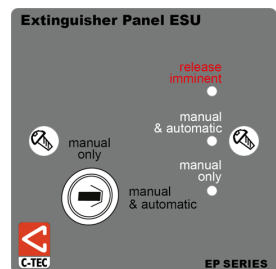

### System Hold Off / Abort Button - Part No. EP215

- Monitored input to the EP203 panel.
- Used to either delay, or cancel the extinguishant release sequence (dependent on connection to EP203 panel).
- Connects to EP203 panel via 2-wire connection. The remaining EP215 units are then daisy-chained.
- Single-gang, surface-mounted unit.
- 6K8 EOL resistor fitted in last EP215 allows wiring to be monitored for open and short-circuit faults.
- Instruction document no. DFU0215000.





## INSTALLATION AND WIRING

### The EP203 Panel Enclosure

The EP203 panel enclosure comprises of a plastic detachable lid and metal base unit containing:

- Main Control PCB - provides all the connections for the system's detector circuits, sounder circuits, monitored inputs and auxiliary outputs. It also provides the engineer with access to a wide range of commissioning and engineering menus
- Power Supply PCB - provides connections to the mains supply. It is switch mode type, rated @230Vac, 50/60Hz that combines the functions of a power supply unit, battery charging unit and battery monitoring unit
- Output Expansion Relay Board (optional) - provides up to five volt-free relay outputs.

The Main Control PCB is mounted on a metal bridge and the Power Supply PCB and optional Output Expansion Relay Board are mounted in the metal base unit underneath the Main Control PCB.

### Removing the Lid and Base PCBs

To protect the electronics from damage and to expose the base mounting holes, the panel's lid and PCBs should be removed prior to first fix installation. See steps below.



#### Anti-static handling guidelines

Ensure that the following electro-static handling precautions are taken immediately prior to handling the panel's PCBs, or any other static-sensitive components. Before handling any static-sensitive items, operators should rid themselves of any personal electro-static charge by momentarily touching any sound connection to safety earth, e.g. a radiator. Always handle PCBs by their sides and avoid touching the legs of any components.

1. Take the panel out of its packing box and undo the two lid screws using the Allen key supplied in the accessory pack.
2. Open the plastic lid, pull out the lid's two fixing pins and take off the lid.
3. Slacken the four M4 retaining nuts on the metal bridge and slide the bridge (and mounted Main Control PCB) up and over the mounting pillars, taking care not to damage any of the components.
4. Disconnect the telecoms-style connecting cables from PL3 on the Power Supply PCB, and from PL1 on the Output Expansion Relay Board (if fitted). Make sure that these cables remain connected to the Main Control PCB to prevent them being misplaced.  
**Note:** Care should be taken when detaching this connector to depress the locking tab to prevent damage.
5. Pull the Power Supply PCB's earth strap (green/yellow) off the spade connector at the main chassis earth point on the base unit.
6. Carefully remove the two retaining screws on the Power Supply PCB and slide the PCB up and over its mounting pillars, taking care not to damage any of the components.
7. If an Output Expansion Relay Board is fitted, carefully remove the two retaining screws on the board and slide the board up and over its mounting pillars, taking care not to damage any of the components.
8. Store the PCBs in a clean, dry place that is free from vibration, dust, and excessive heat. Storing the PCBs in a suitable cardboard box will also guard them against mechanical damage.

## FIRST FIX

### Cable Types and Limitations

Consult Clause 26 of BS 5839: Pt 1: 2002 Fire Detection and Alarm Systems for Buildings (Code of Practice for System Design, Installation, Commissioning and Maintenance) for detailed information on cables, wiring and other interconnections.

All system wiring should be installed in accordance with the current edition of the IEE Wiring Regs, (BS 7671), or other national standards of installation should be used where applicable.

To comply with EMC (Electro Magnetic Compatibility) regulations and to reduce the risk of electrical interference in the system wiring, we recommend the use of fire-resistant screened cables throughout the installation.

### Planning the Cable Entry and Distribution within the EP203 Panel

**Note:** The detector and alarm sounder circuit cabling is classed as low voltage and must be segregated away from mains voltages. Careful planning is needed to ensure this. See Figure 2 below for guidance.

We recommend that field wiring tails of at least 20-30cm are left inside the EP203 panel enclosure to ensure adequate connection to the EP203 panel terminals.

All cables should be fed into the EP203 panel via the knockouts provided on the top of the base unit. Knockouts should be removed with a sharp, light tap using a flat 6mm broadsided screwdriver, as shown in diagram (right).

Always ensure that if a knockout is removed, the hole is filled with a good quality 20mm cable gland. Any unused knockouts must be securely blanked off.

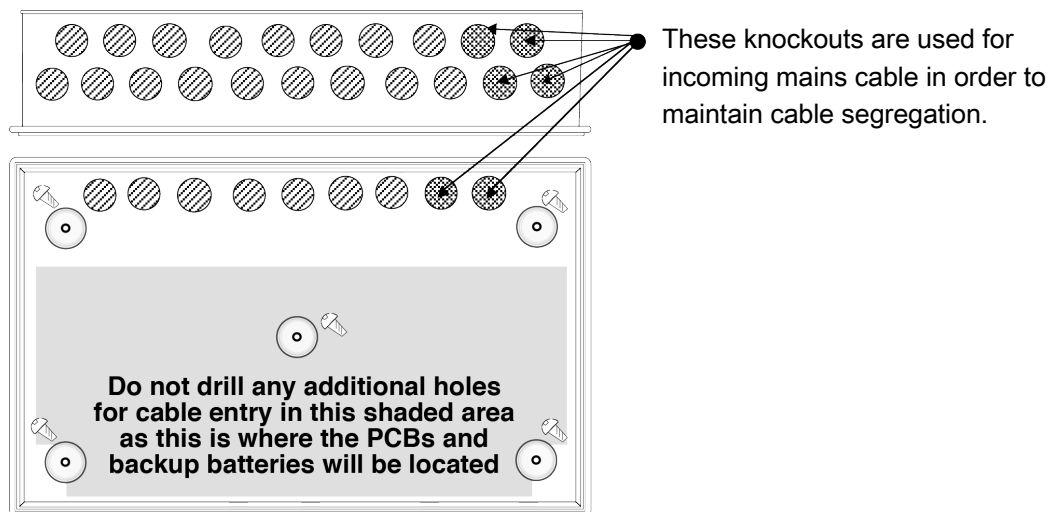
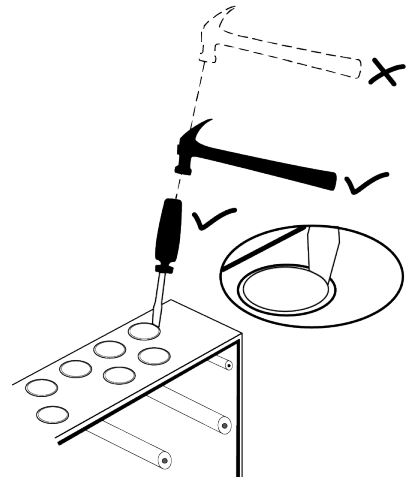

Figure 2 : Location of Enclosure Mounting Holes and Knockouts

### Siting and Mounting the EP203 Panel

The EP203 panel enclosure can be surface, or semi-flush mounted. It must be sited indoors on a dry, flat surface in an area not subject to conditions likely to affect its performance, e.g. damp, salt-air, water ingress, extremes of temperature, physical abuse, etc. It should be sited at a height where it is easily accessible and in a prominent position within the building. Ideally, the LED indicators and LCD unit on the front of the enclosure should be at eye level.

To expose the EP203 panel's mounting holes, the lid and base PCBs have to be removed (see Page 9). Using the five mounting holes provided, fix the base securely onto the wall. The mounting holes are suitable for use with No.8-10, or 4-5mm countersunk screws. Assess the condition and construction of the wall and use suitable screw fixings.

**Note:** The central mounting hole can be used to temporarily hang the base unit so it can be levelled and its remaining fixing points marked for drilling.

Any dust, or swarf created during the fixing process must be kept out of the enclosure.

### Mains Wiring

All wiring should be installed in accordance with the current edition of the IEE Wiring Regs (BS 7671), or relevant local and national standards. The requirement for the mains supply to the panel's PSU is fixed wiring ( $\geq 1.0 \text{ mm}^2$ ,  $< 2.5 \text{ mm}^2$ ), either using 3-core cable, or a suitable three conductor system fed from an isolating switched fused spur at 3 A, or a 6 A Type B circuit breaker to IEC/EN 60898-1. The mains supply must be exclusive to the PSU and be reliably earthed at the indicated earthing point. This should be secure from unauthorised operation and be marked 'FIRE ALARM: DO NOT SWITCH OFF'. The mains supply must be exclusive to the EP203 panel.

**HINT:** As an alternative to a switched fused spur, a double-pole isolating switch with 3 mm air gaps on the contacts & switching L & N only, may be used in the mains feed from the Main Distribution Board to the PSU, providing it meets the appropriate wiring regulations (see Figure 3 below).

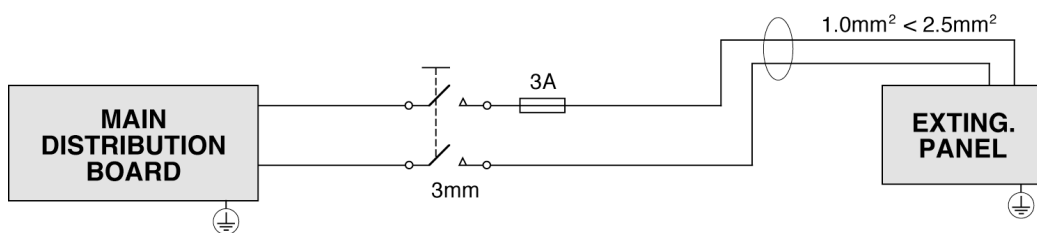

Figure 3 : Mains Wiring

**Note:** The mains supply wiring MUST be segregated away from the detector and alarm sounder circuit cabling which is classed as low voltage.

## Detector Circuit Wiring

**Note:** See Appendix 4 (Technical Specification) for the detector circuit specification.

The EP203 panel can power three conventional detector circuits at 19-28Vdc. Each detector circuit must be wired as a single, radial circuit with no spurs. **Detector bases with integral continuity diodes MUST NOT be used and manual call points MUST NOT be connected to the detector circuits.**

**Note:** The total number of detectors affects the system standby time and should be taken into account when selecting the standby battery. See Appendix 1 for standby battery calculation.

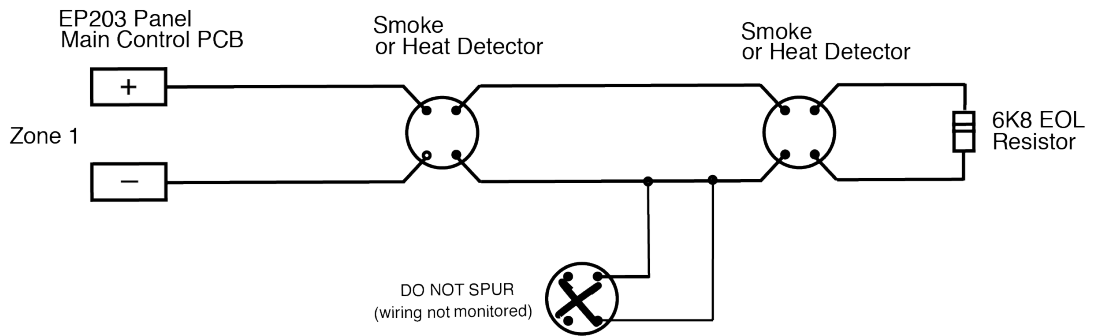

Figure 4 : Typical Detector Circuit Wiring

A 6k8 end-of-line resistor (supplied in the accessory pack) must be connected across the terminals of the last device on each circuit to allow the wiring to be line monitored for open and short circuit faults.

**Note:** Unused circuits must have a 6k8 resistor fitted at the EP203 panel terminals.

The wiring for each detector circuit should be connected to the relevant 5mm connector block on the Main Control PCB (Zone 1, Zone 2, or Zone 3) and their screens terminated at the EP203 panel's base earth post. For more specific device wiring information, refer to the manufacturers' own instructions.

## Sounder Circuit Wiring

**Note:** See Appendix 4 (Technical Specification) for the sounder circuit specification.

The EP203 panel can power three conventional polarised sounder circuits at 19-28Vdc. Each sounder circuit must be wired as a single, radial circuit with no spurs.

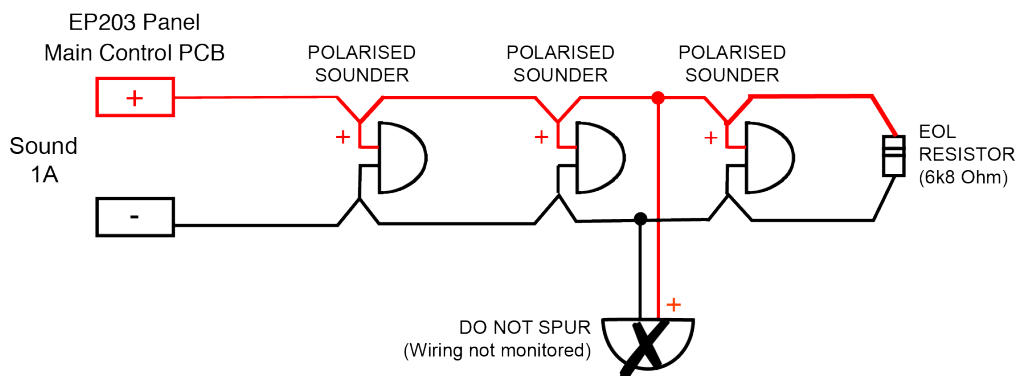

Figure 5 : Typical Sounder Circuit Wiring

## EP203 AUTOMATIC EXTINGUISHER PANEL

A 6k8 end-of-line resistor (supplied in the accessory pack) must be connected across the terminals of the last device on each circuit to allow the wiring to be line monitored for open and short circuit faults.

**Note:** Unused circuits must have a 6k8 resistor fitted at the EP203 panel terminals.

The wiring for each alarm sounder circuit should be connected to the relevant 5mm connector block on the Main Control PCB (Sound 1A, Sound 1B, Sound 2nd Stage) and their screens terminated at the EP203 panel's base earth post. For more specific device wiring information, refer to the manufacturers' own instructions.

### Monitored Input Wiring

**Note:** See Appendix 4 (Technical Specification) for the monitored input specification.

Six monitored input connections are available at the EP203 panel:

Manual Release, Flow Switch, Low Pressure, Mode, Hold and Abort.

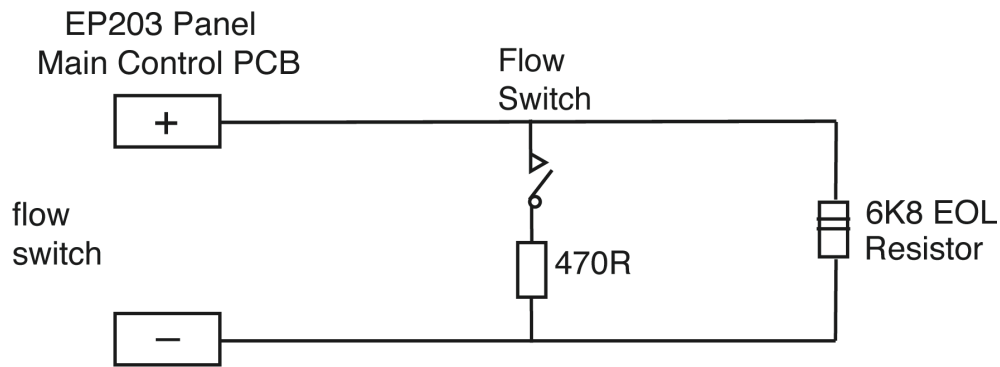

Figure 6 : Typical Monitored Input Wiring

A 6k8 end-of-line resistor (supplied in the accessory pack) must be connected across the terminals of each device on each circuit to allow the wiring to be line monitored for open and short circuit faults.

**Note:** Unused circuits must have a 6k8 resistor fitted at the EP203 panel terminals.

The wiring for each input should be connected to the relevant 5mm connector block on the Main Control PCB and their screens terminated at the EP203 panel's base earth post.

### Auxiliary Output Wiring

**Note:** See Appendix 4 (Technical Specification) for the auxiliary output circuit specification.

The wiring for each output should be connected to the relevant 5mm connector block on the Main Control PCB and their screens terminated at the EP203 panel's base earth post.

Six auxiliary relays provide volt-free changeover contacts, as detailed below:

- **Fire:** Relay energises on any fire condition, or by pressing the Silence/Resound Sounder pushbutton. Relay will not operate on activation of a remote control AL input. Relay de-energises on panel reset.
- **Local Fire:** Relay operates when 1st stage sounders are active, or by pressing Silence/Resound Sounder pushbutton. Relay de-energises when 1st stage sounders are reset.

## EP203 AUTOMATIC EXTINGUISHER PANEL

- **1st Stage Alarm:** Relay operates when 1st stage sounders are active, or when the panel mounted (or remote manual) release pushbutton is pressed. The relay remains activated until the panel is reset.
- **2nd Stage Alarm:** Relay operates when 2nd stage sounders are active, or when the panel mounted (or remote manual) release pushbutton is pressed. The relay remains activated until the panel is reset.
- **Fault:** This relay output is normally energised. When a fault occurs, the output turns off to ensure failsafe operation even in the event of total power loss.
- **Extract:** Relay operates when an Access Level 2 user selects Start Extract Fan after the flooding time has elapsed (without a reset). This allows a flooded area to be vented of extinguishant.  
**Note:** The Extract Option is enabled/disabled in the Commissioning menu at Access Level 3.

### Remote Inputs & Aux Output Wiring

If required, some functions of the EP203 can be remotely controlled. The operating inputs of the remote equipment is restricted to an Access Level 2 user. The wiring for each input should be connected to the relevant 5mm connector block on the Main Control PCB and their screens terminated at the EP203 panel's base earth post. Total wiring length for each circuit < 30 metres.

The 4 x remote inputs and 1 x aux output functions at the Main Control PCB are listed below:

- **+/-:** Aux Output (power)
- **SIL:** Silence Alarm
- **AL:** Sound Alarm
- **FLT:** Fault – Generates a general fault and operates the fault relay.
- **RST:** Reset – Resets the system to normal mode.

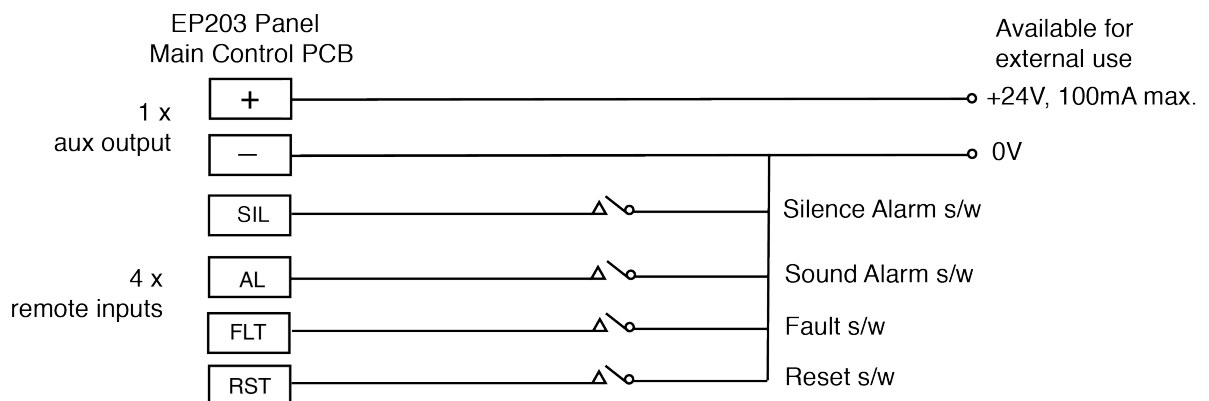

Figure 7 : Typical Remote Inputs & Aux Output Wiring

## Extinguisher Output Wiring

**Note:** See Appendix 4 (Technical Specification) for the extinguisher output circuit specification.

The wiring for each output should be connected to the relevant 5mm connector block on the Main Control PCB and their screens terminated at the EP203 panel's base earth post.

The EP203 panel's extinguishant outputs supports up to two solenoids, or multiple 'Metrons™' (typically up to four).

### Solenoid Wiring

The extinguishant output is capable of supplying up to 1 amp for the maximum duration (5 mins.) to a solenoid. To ensure that the current rating of the extinguishant output is not exceeded:

- If one solenoid is used it must have a resistance greater than 30 ohms
- If two solenoids are used each solenoid must have a resistance greater than 60 ohms.

**Note:** The number of EP214 System Line Terminators is programmed by an Access Level 3 user in the Commissioning menu (Ext. O/P EOLs sub-menu).

**Wiring for one solenoid:**

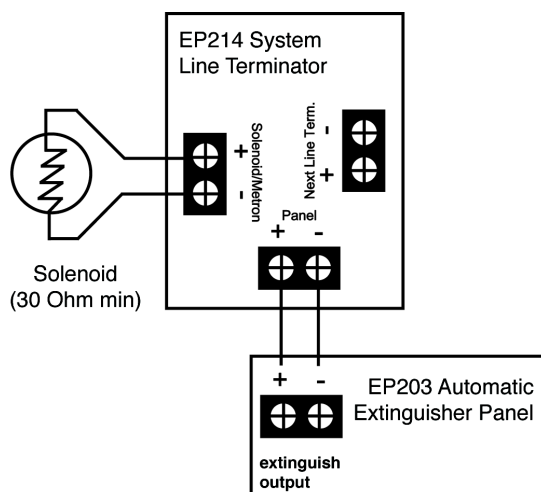

**Wiring for two solenoids:**

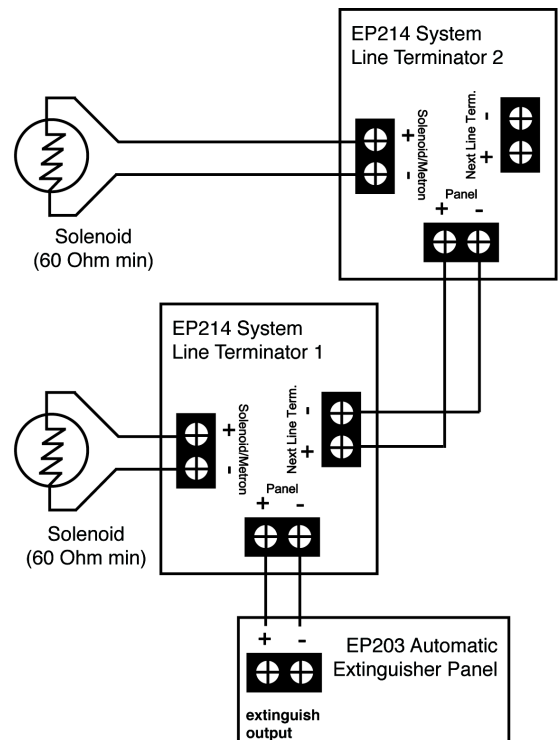

Figure 8 : Typical Solenoid Circuit Wiring

## EP203 AUTOMATIC EXTINGUISHER PANEL

### Igniting Actuator (Metron™) Wiring

The extinguishant output is capable of supplying up to 3 amps for the maximum duration (50 milliseconds) to an igniting actuator.

The total series resistance of the actuator(s) and wiring should NOT exceed 7 ohms.

#### Wiring for one actuator:

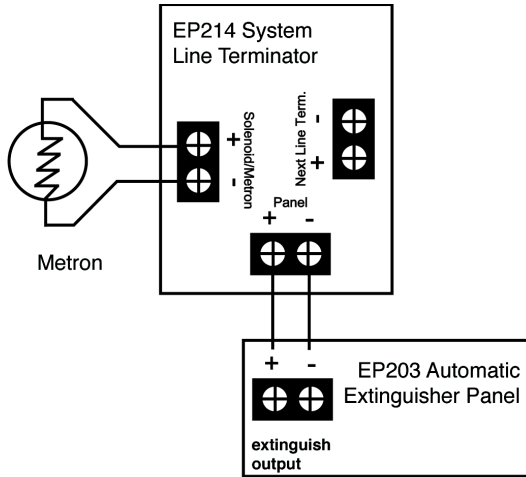

#### Wiring for multiple actuators:

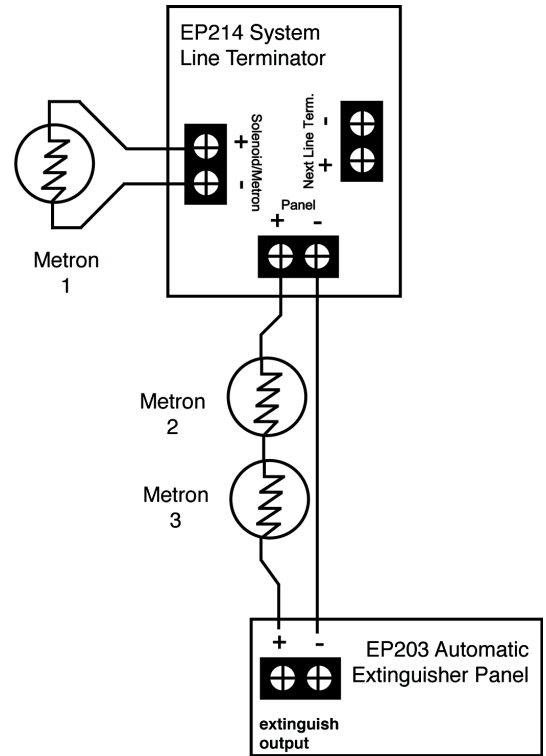

Figure 9 : Typical Igniting Actuator Circuit Wiring



## Connection to RSUs and ESUs

RSUs require a 4-wire connection (2-wire power, 2-wire RS485) from the EP203 panel that connects to each unit and is daisy chained onto the next (see Figure 10 below). Total wiring length < 30 metres.

The RSU abbreviated functions at the Main Control PCB are listed below:

- **+/-**: 2-wire power supply (24V); **A/B**: 2-wire RS485 data connection

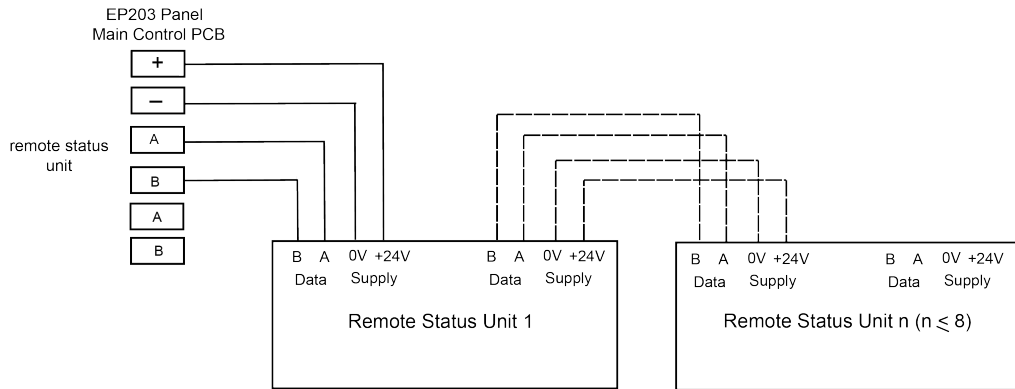

Figure 10 : Typical RSU Circuit Wiring

Each RSU has a pcb-mounted DIL switch and must be allocated a unique address between 1 and 8. See right for DIL switch settings (●=DIL switch ON/UP).

Each RSU has a pcb-mounted Display Contrast (VR1) that can be adjusted to suit the contrast of the units' LCD display.

ESUs require a 2-wire 24V power connection and 2-wire mode select from the EP203 panel that connects to each unit and is daisy chained onto the next (see Figure 11 below). Total wiring length < 30 metres.

A 6k8 end-of-line resistor (supplied in the accessory pack) must be connected across the terminals of the last ECU on each circuit to allow the wiring to be line monitored for open and short circuit faults.

RSU Address	DIL Switch Settings			
	8	4	2	1
1	○	○	○	●
2	○	○	●	○
3	○	○	●	●
4	○	●	○	○
5	○	●	○	●
6	○	●	●	○
7	○	●	●	●
8	●	○	○	○

**Note:** Unused circuits must have a 6k8 resistor fitted at the EP203 panel terminals.

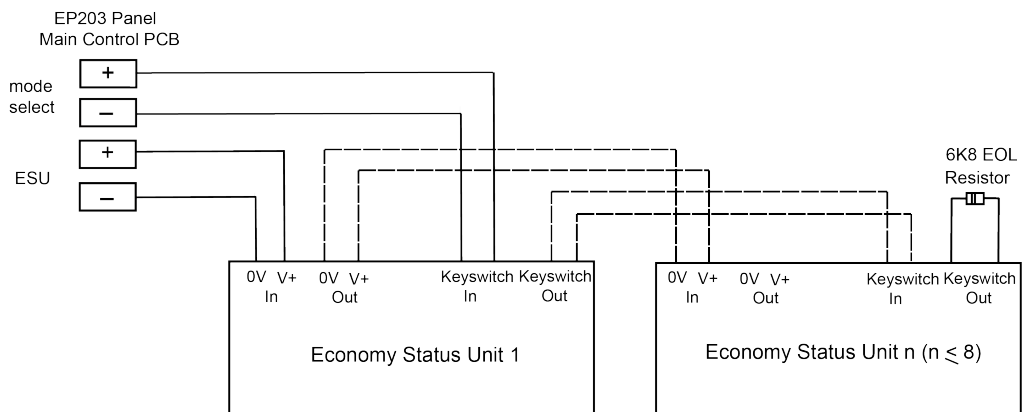

Figure 11 : Typical ESU Circuit Wiring

## **SECOND FIX**

### **Connecting the EP203 Panel**

**CAUTION: DO NOT use a high voltage insulation tester with any electronic devices connected.**

Check all devices on the detector and sounder circuits are correctly connected and that cable integrity is verified throughout the installation. Faults occurring in the wiring, which are not identified at this stage, will almost certainly result in spurious and intermittent faults when the equipment is energised.

### **Installing the Power Supply PCB and Output Expansion Relay Board**

**WARNING: WHEN CONNECTED, THE POWER SUPPLY PCB STORES VOLTAGES UP TO 400Vdc AND MAY BE LETHAL IF TOUCHED. DO NOT TOUCH THE PCB WHILST THE (HAZARDOUS VOLTAGES PRESENT) RED LED IS LIT ON THE PCB.**

The component layout of the Power Supply PCB is shown in Figure 12.

1. Slide the Power Supply PCB over and downwards securing onto its mounting pillars, taking care not to damage any of the components.
2. Fix the two retaining screws on the Power Supply PCB. Do not overtighten the screws otherwise their threads will strip.
3. Attach the Power Supply PCB's earth strap (Green/Yellow) to the spade connector at the main chassis earth point on the base unit.
4. If an Output Expansion Relay Board is fitted, carefully slide the board over and downward securing onto its mounting pillars, taking care not to damage any of the components.
5. Fix the two retaining screws on the Output Expansion Relay Board. Do not overtighten the screws otherwise their threads will strip.

### **Connecting the Mains Supply**

The general requirement for the mains supply to this equipment is described on Page 11.



**WARNING: DO NOT ATTEMPT TO CONNECT THE MAINS SUPPLY TO THE POWER SUPPLY PCB UNLESS THE INSTALLATION IS COMPLETE AND ALL PCBs ARE SECURELY INSTALLED IN THE EP203 PANEL.**

The incoming mains cable should enter the EP203 panel through the knockouts at the top right hand side of the enclosure and terminated at the connector block (CONN1) on the Power Supply PCB. Make sure the mains earth wire is connected directly to this connector block and NOT to the secondary base earth post (which is provided for connecting detector and sounder circuit screens).

The Power Supply PCB's earth strap MUST be connected to the spade on the chassis earth post before operation.

# EP203 AUTOMATIC EXTINGUISHER PANEL

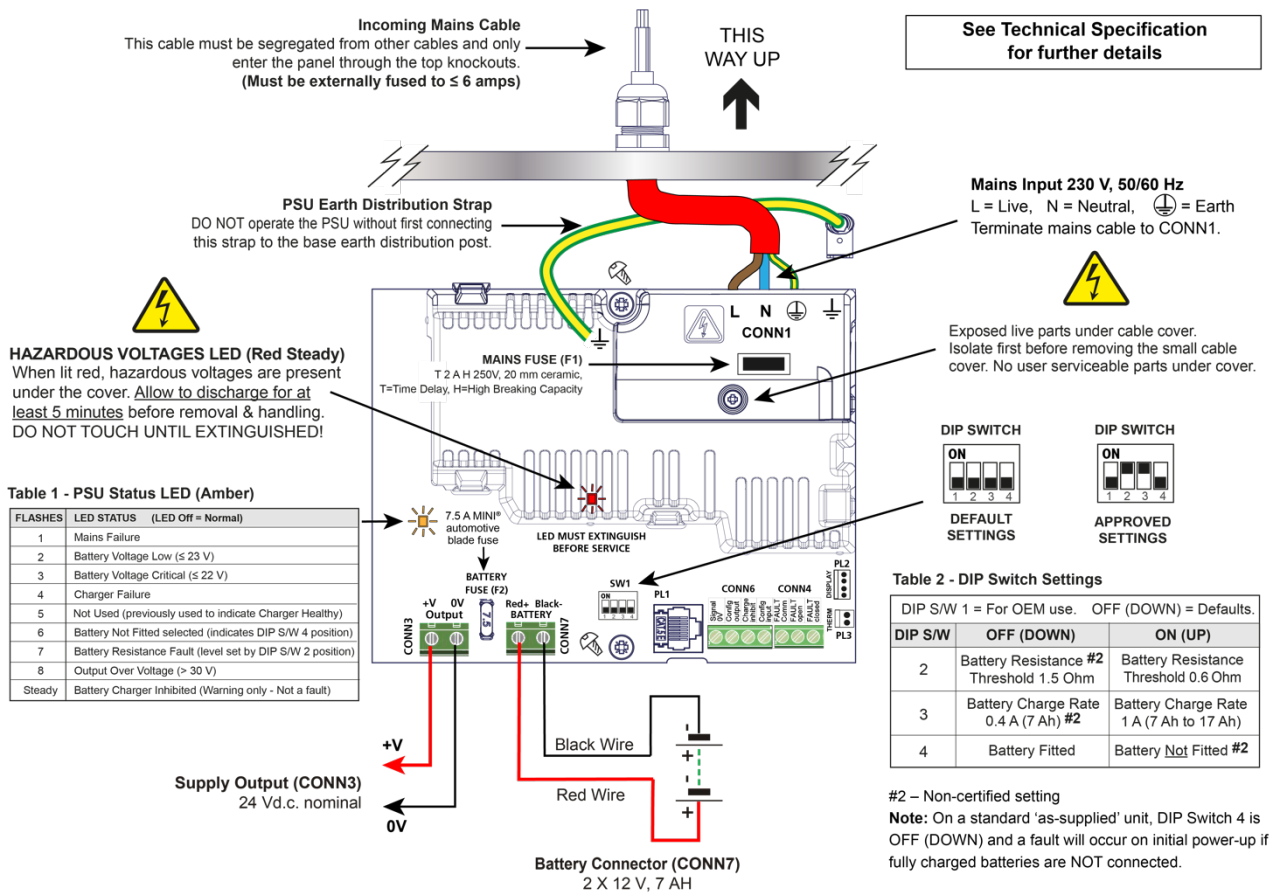

Figure 12 : Power Supply PCB Layout and Connection Details

## Connecting the Standby Batteries

**CAUTION:** Always dispose of used batteries in accordance with the battery manufacturers' instructions. There is a risk of explosion if batteries are replaced by an incorrect type.

Two, new high quality and fully charged 12V, 7Ah valve regulated lead-acid (VRLA) type batteries are required as the emergency standby power supply for the EP203 panel.

To calculate the batteries required for any given standby period, refer to the calculation guide in Appendix 1. The batteries should be connected in series and located in the EP203 panel's enclosure as shown in Figure 13, below.

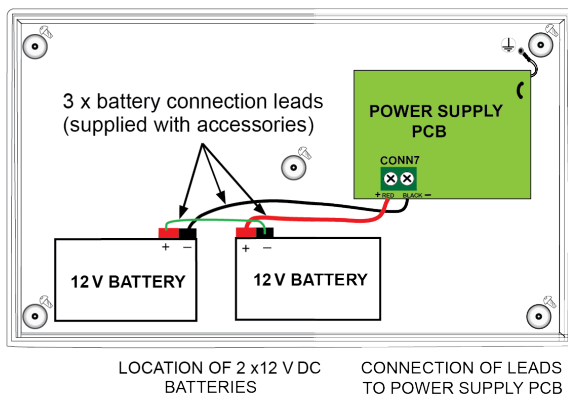

Figure 13 : Battery Location and Connection Details

**Note:** The battery connection leads (red lead, black lead and green link wire) are supplied in the accessory pack.

The EP203 panel's sophisticated battery monitoring unit protects the batteries against deep discharge by activating a cut off circuit when the standby supply voltage reaches approx. 21V. If batteries are not fitted, are discharged, or in poor condition, a PSU fault will be displayed at the EP203 panel.

### Installing the Main Control PCB

The connections to the panel's Main Control PCB are shown in Appendix 2.

**Note:** Before any connections are made, the Main Control PCB and Output Expansion Relay Board (if fitted) must first be securely mounted inside the base unit.

1. Slide the metal bridge (and mounted Main Control PCB) over and downwards securing onto its mounting pillars.
2. Secure the metal bridge in the base unit using the four M4 retaining nuts, taking care not to damage any of the components. Do not overtighten the nuts otherwise their threads will strip.
3. Connect the Main Control PCB's telecoms-style connecting cables to PL3 on the Power Supply PCB and to PL1 on the Output Expansion Relay Board (if fitted).

**Note:** Care should be taken when attaching this connector to depress the locking tab to prevent damage.

### Connecting Circuits to the Main Control PCB

Incoming detector and sounder circuits, monitored inputs, auxiliary outputs, extinguisher circuits, RSUs and ESUs are be connected to the relevant connector block on the Main Control PCB as shown in Appendix 2. For typical circuit wiring diagrams refer to the First Fix section of this manual. See note below regarding earthing of screens.

#### Important notes regarding the earthing of screens



All screens should be adequately insulated and connected between the nut and washers on the base earth post (see right) using suitable eyed crimp connectors.

Do not disturb the lower nut, this must be secure to ensure earth continuity. The base earth post is provided for terminating earth screens, or drains and not as the main earthing point. The system designer, or installer must review the external earth bonding (if required) with respect to the national wiring rules.

That is, if the type of installation requires protective earth bonding, then this must be applied externally and in conjunction with the type of earthing system employed on that particular site.

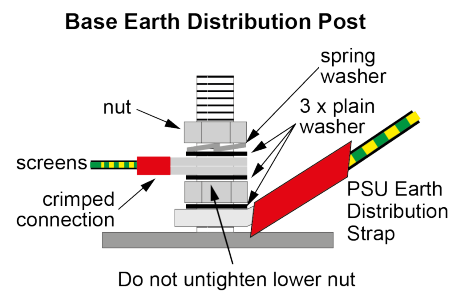

## **PROGRAMMING THE EP203 PANEL**

Three levels of control are available on the EP203 panel: General User (Access Level 1), Authorised User (Access Level 2) and Engineer (Access Level 3) as detailed below:

**Note:** For detailed information on how to use the general and authorised user controls, refer to the EP203 panel User Manual/Log Book (Approved Document No. DFU0002031).

### **General User Controls (Access Level 1)**

The functions that can be performed in Access Level 1 are:

- Manually activate the extinguishant release
- Mute the internal sounder.

Also, by pressing the 'menu' button, the LCD unit displays the following Access Level 1 menu:



Display Faults  
Display Dis/mnt  
Zones in Test  
Lamp Test  
Alarm Counter

### **Authorised User Controls (Access Level 2)**

The functions that can be performed in Access Level 2, by turning the panel-mounted keyswitch to the accessed position "I" are:

- Manually activate the extinguishant release
- Mute the internal sounder
- Silence the alarm sounders
- Resound the alarm sounders
- Reset an alarm condition.

Also, the LCD unit displays the following Access Level 2 menu:



Display Faults  
Display Dis/mnt  
Zones in Test  
Lamp Test  
Alarm Counter  
Set Time/Date  
Event Log  
Disp Contrast  
Disablements

### Engineer Controls (Access Level 3)

To avoid unauthorised changes to critical parts of the control system, certain EP203 panel functions are only available to engineers and competent service personnel.

The functions that can be performed in Access Level 3, by pressing the Access level 3 switch (mounted on the Main Control PCB) are:

- Manually activate the extinguishant release
- Silence the internal sounder
- Silence the alarm sounders
- Resound the alarm sounders
- Reset an alarm condition.

Also, the LCD unit displays the following Access Level 3 menu:

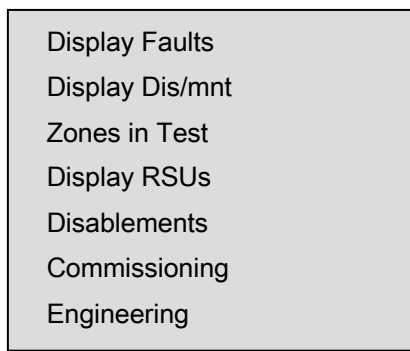

### Accessing and using the Engineer Controls

To gain access to the engineer's menu and sub-menus:

1. Open the EP203 panel front lid using the Allen key supplied in the accessory pack.
2. Press the Access level 3 switch located at the top right corner on the Main Control PCB. The Accessed yellow LED will be lit steady and the Access Level 3 menu is displayed on the LCD unit.
3. Press the Scroll (up) ▲ and Scroll (down) ▼ buttons to highlight a menu.
4. Press the Accept ► button to select a menu and a sub-menu is displayed.
5. Press the Accept ► button to select a sub-menu.
6. If applicable, press the Scroll (up) ▲ and Scroll (down) ▼ buttons to scroll the display through all active conditions (faults, disablements, tests, etc.).
7. Press the Escape ◀ button to return to the previous Access Level 3 menu.
8. To escape Access Level 3 press the Access level 3 switch.

**Note:** The panel will automatically exit the Access Level 3 menu after approx. 1 hour of inactivity.

## **ACCESS LEVEL 3 MENUS**

### **Overview**

<b>Menu</b>	<b>Sub-Menu</b>	<b>Description</b>
<b>Display Faults</b>	n/a	Displays all faults on the system
<b>Display Dis/mnt</b>	n/a	Displays all disablements on the system
<b>Zones in Test</b>	n/a	Displays all detection zones that are in test mode on the system
<b>Display RSUs</b>	n/a	Displays all Remote Status Units connected on the system
<b>Disablements</b>	Disable Exting	Disables/enables the extinguishant system
	Disable Zone	Disables/enables detection zones
	Disable Sounder	Disables/enables fire sounders
	Disable SndrDel	Disables/enables fire sounder delay
	Disable Input	Disables/enables monitored inputs
	Disable Relay	Disables/enables auxiliary relay outputs
	Disable RSU	Disables/enables Remote Status Units
<b>Commissioning</b>	Zone Selection	Selects the zone combination that starts the extinguishant release sequence
	Ext. Delay	Sets the countdown duration before the release of extinguishant
	Ext. Duration	Sets the duration of the firing signal to the extinguishant output
	Flooding Time	Sets the duration for release of extinguishant
	Extract Option	Selects the ventilation extract option
	Extract Time	Sets the duration for the ventilation extract fan operation
	Flow Option	Selects the flow switch
	Sounder Delay	Sets the delay duration before the fire sounders are activated
	RSU Learn	Finds all RSUs on the system and updates the panel's database
	Ext. O/P EOLs	Selects the number of extinguisher circuit terminations
	Mode Exceptions	Selects default setting mode when the mode input is in Fault and/or Disabled
	Earth Fault	Disables/enables the panel's earth fault monitoring circuitry. <b>Note:</b> Earth fault monitoring must be enabled to meet the requirements of EN 54-2 / EN 12094-1.
	Man Rel Mode	Selects either delayed, or immediate release of extinguishant
	Zone Trigger	Enables a short circuit condition on the three detection zones
	Resound Fire	Disables/enables the panel's resound on fire
	Clean Start	Clears the panel's memory back to its default factory settings
<b>Engineering</b>	Walk Test	Puts detection zone(s) into walk test mode
	Test Relays	Tests the panel's auxiliary relay outputs
	Test Sounders	Tests the panel's sounder circuits
	Monitoring	Applies a constant monitoring voltage
	Show PSU Stats	Displays status of the panel's PSU and standby battery
	Version Numbers	Displays the panel's software version and checksum

**Note:** A Stop Flooding 'floating' menu is also displayed for a level 3 user when an extinguishant release is in progress. Selecting this menu terminates the release of extinguishant.

## Display Faults

This menu displays all faults on the system and is available at both Access Levels 2 and 3:

1. In Access Level 3, select the Display Faults menu. The panel displays all active faults on the system. (e.g. Zone 1 O/C Fault, Zone 2 S/C Fault, etc.)
2. Scroll the display through all active faults using the Scroll (up) ▲ and Scroll (down) ▼ buttons.
3. Press the Escape ◀ button to return to the Access Level 3 menu.

## Display Dis/mnt

The Display Disablements menu displays all active disablements on the system and is available at both Access Levels 2 and 3. Disablements are set in the Disablements menu (see Page 25-26).

1. In Access Level 3, select the Display Dis/mnt menu. The panel displays all active disablements on the system (e.g. Zone 1 disabled, etc.).
2. Scroll the display through all active disablements using the Scroll (up) ▲ and Scroll (down) ▼ buttons.
3. Press the Escape ◀ button to return to the Access Level 3 menu.

## Zones in Test

This menu displays all detection zones that are currently in test mode on the system and is available at both Access Levels 2 and 3. Zones are put in test mode in the Engineering menu (see Page 31).

1. In Access Level 3, select the Zones in Test menu. The panel displays all zones currently in test on the system (e.g. Zone 1 is on Test, etc.).
2. Scroll the display through all active zones in test using the Scroll (up) ▲ and Scroll (down) ▲ buttons.
3. Press the Escape ◀ button to return to the Access Level 3 menu.

## Display RSUs

This menu displays all active Remote Status Units on the system.

1. In Access Level 3, select the Display RSUs menu. The panel automatically displays all RSUs and their IDs.
2. Press the Escape ◀ button to return to the Access Level 3 menu.



## Disabling

The Disabling menu allows the temporary disabling, or enabling of the extinguishant system, detection zones, sounders, monitored inputs, relays and RSUs. The Disabling menu is available at both Access Levels 2 and 3.

Any active disabling are displayed at the EP203 panel by the General Disablement and relevant disablement yellow LEDs lit steady.

**Note:** It is recommended all disabling are immediately enabled when no longer required as they can have a major effect on how the system works.

### Disable Exting

This sub-menu allows the disabling/enabling of the extinguishant system.

1. From the Disabling menu select the Disable Exting sub-menu.
2. Press the Accept ► button to disable/enable the extinguishant system.
3. Press the Escape ◀ button to return to the Disabling menu.

**Note:** 'Exting System Disabled' will also be displayed at any RSUs connected on the system.

### Disable Zone

This sub-menu allows the disabling/enabling of one, or more of the panel's three detection zones. Disabled zones do not report fire, or fault conditions.

1. From the Disabling menu select the Disable Zone sub-menu.
2. Select the detection zone(s) to be disabled/enabled using the Scroll (up) ▲ and Scroll (down) ▼ buttons.
3. Press the Accept ► button to disable/enable a selected zone.
4. Press the Escape ◀ button to return to the Disabling menu.

### Disable Sounder

This sub-menu allows the disabling/enabling of the fire sounders from sounding in a fire condition.

1. From the Disabling menu select Disable Sounder.
2. Press the Accept ► button to disable/enable the sounder circuit.
3. Press the Escape ◀ button to return to the Disabling menu.

### Disable SndrDel

The sounder delay sub-menu allows the disabling/enabling of a fire sounder delay in a fire condition.

1. From the Disabling menu select Disable SndrDel.
2. Press the Accept ► button to disable/enable the delay on the sounder circuit.
3. Press the Escape ◀ button to return to the Disabling menu.

### Disable Input

This sub-menu allows the disabling/enabling of one, or more of the panel's six monitored inputs: Manual Release, Flow Switch, Low Pressure, Mode, Hold and Abort.

1. From the Disablements menu select Disable Input.
2. Select the input(s) to be disabled/enabled using the Scroll (up) ▲ and Scroll (down) ▼ buttons.
3. Press the Accept ► button to disable/enable the selected input.
4. Press the Escape ◀ button to return to the Disablements menu.

### Disable Relay

This sub-menu allows the disabling/enabling of one, or more of the panel's six auxiliary relay outputs: Fire, Local Fire, Extract, 1st Stage\*, 2nd Stage\* and Fault\*\*.

**Note:** If an Output Expansion Relay Board is fitted, this sub-menu also allows the disabling/enabling of one, or more of the board's five relay outputs: Reset, Mode, Discharged, Hold and Abort.

1. From the Disablements menu select Disable Relay.
2. Select the relay output(s) to be disabled/enabled using the Scroll (up) ▲ and Scroll (down) ▼ buttons.
3. Press the Accept ► button to disable/enable the selected relay output.
4. Press the Escape ◀ button to return to the Disablements menu.



\* **Note 1:** If the 1st and 2nd stage relay outputs are both disabled followed by an extinguishant released condition, then re-enabling the 1st and 2nd stage relay outputs results in only the 1st stage relay output being activated.

However, subsequent extinguishant release conditions will cause the 2nd stage relay to be activated as expected.

\*\* **Note 2:** Disabling the fault relay output makes the system non-compliant with EN 54-2.

### Disable RSU

This sub-menu allows the disabling/enabling of one, or more of the panel's Remote Status Units.

1. From the Disablements menu select Disable RSU.
2. Select the RSU(s) to be disabled/enabled using the Scroll (up) ▲ and Scroll (down) ▼ buttons.
3. Press the Accept ► button. The panel requests confirmation.
4. Scroll (down) ▼ button to confirm the change.
5. Press the Accept ► button to disable/enable the selected RSU. The Disablements menu is displayed.

**Note:** 'RSU Disabled' will be displayed at the RSU that has been disabled.

## Commissioning

### Zone Selection

This sub-menu programs the zone combination that starts the extinguishant release sequence.

1. From the Commissioning menu select Zone Selection.
2. Highlight the required zone selection using the Scroll (up) ▲ and Scroll (down) ▼ buttons. The options are listed below:
  - NONE (**Note:** This option should not be selected if EN 12094-1 compliance is required)
  - Z1 & Z2, Z2 & Z3, Z1 & Z3, Z1 & Z2 & Z3
  - Z1 OR Z2, Z2 OR Z3, Z1 OR Z3, Z1 OR Z2 OR Z3
  - (Z1 & Z2) OR (Z1 & Z3), (Z1 & Z3) OR (Z2 & Z3), (Z2 & Z1) OR (Z2 & Z3)
  - (Z1 & Z2) OR Z3, (Z1 & Z3) OR Z2, (Z2 & Z3) OR Z1
  - ANY PAIR
  - ANY SINGLE ZONE
3. Press the Accept ► button to confirm the zone selection. The Commissioning menu is displayed.

### Ext. Delay

The extinguishant delay sub-menu sets the countdown duration before the extinguishant is released.

1. From the Commissioning menu select Ext. Delay.
2. Select the required duration using the Scroll (up) ▲ and Scroll (down) ▼ buttons. This is adjustable between 0-60 seconds (in 1 second steps).
3. Press the Accept ► button to confirm the changes. The Commissioning menu is displayed.

### Ext. Duration

The extinguishant duration sub-menu sets the duration of the firing signal to the extinguishant output, typically 2 secs.

**Note:** Keep the extinguishant duration to a minimum in order to minimize current consumption.

1. From the Commissioning menu select Ext. Duration.
2. Select the required duration using the Scroll (up) ▲ and Scroll (down) ▼ buttons. This is adjustable between 1-300 seconds (in 1 second steps).
3. Press the Accept ► button to confirm the changes. The Commissioning menu is displayed.

### Flooding Time

This sub-menu sets the flooding time.

1. From the Commissioning menu select Flooding Time.
2. Select the required duration using the Scroll (up) ▲ and Scroll (down) ▼ buttons. This is adjustable between 60-1740 seconds (in 1 second steps).
3. Press the Accept ► button to confirm the changes. The Commissioning menu is displayed.

### Extract Option

This sub-menu selects whether the ventilation extract fan is fitted, or not.

1. From the Commissioning menu select Extract Option.
2. Select either the extract fitted, or not fitted option using the Scroll (up) ▲ and Scroll (down) ▼ buttons.
3. Press the Accept ► button to confirm the changes. The Commissioning menu is displayed.

### Extract Time

This sub-menu sets the duration for operation of the ventilation extract fan, which vents a flooded area of extinguishant.

**Note:** The Extract Option has to be enabled (see above).

1. From the Commissioning menu select Extract Time.
2. Select the required duration using the Scroll (up) ▲ and Scroll (down) ▼ buttons. This is adjustable between 1-900 seconds (in 1 second steps).
3. Press the Accept ► button to confirm the changes. The Commissioning menu is displayed.

### Flow Option

This sub-menu selects whether a flow switch is fitted, or not.

1. From the Commissioning menu select Flow Option.
2. Select either the flow switch fitted, or not fitted option using the Scroll (up) ▲ and Scroll (down) ▼ buttons.
3. Press the Accept ► button to confirm the changes. The Commissioning menu is displayed.

### Sounder Delay

When an alarm occurs it is processed as normal, however, the activation of the fire sounders can be postponed until a specified delay period has expired, thus allowing the cause of the alarm to be investigated by the user.

1. From the Commissioning menu select Sounder Delay.
2. Select the required delay period using the Scroll (up) ▲ and Scroll (down) ▼ buttons. This is adjustable between 0-600 seconds (in 1 second steps).
3. Press the Accept ► button to confirm the changes. The Commissioning menu is displayed.

### RSU Learn

This sub-menu initiates an RSU learn operation by the panel and also updates the panel's database.

1. From the Commissioning menu select RSU Learn. The panel automatically performs an RSU learn operation and finds all RSUs on the system.
2. Press the Escape ◀ button to return to the Commissioning menu.

### Ext. O/P EOLs

The extinguishant output end-of-line sub-menu sets the number of extinguisher System Line Terminators to either 1 or 2.

1. From the Commissioning menu select Ext. O/P EOLs.
2. Select the required number of terminations using the Scroll (up) ▲ and Scroll (down) ▼ buttons.
3. Press the Accept ► button to confirm the changes. The Commissioning menu is displayed.

### Mode Exceptions

This sub-menu sets the default setting of mode when the mode input is in fault and/or disabled.

1. From the Commissioning menu select Mode Exceptions.
2. Select either default Mode on Fault, or default Mode on Disable using the Scroll (up) ▲ and Scroll (down) ▼ buttons.
3. Select either Manual Only, or Auto/Manual Mode using the Scroll (up) ▲ and Scroll (down) ▼ buttons.
4. Press the Accept ► button to confirm the mode changes.
5. Press the Escape ◀ button. The Commissioning menu is displayed.

### Earth Fault

This sub-menu enables/disables the earth fault circuitry. **Note:** Earth fault monitoring must be enabled to meet the requirements of EN54-2 / EN 12094-1. Disabling earth fault monitoring makes the installation non-compliant.

1. From the Commissioning menu select Earth Fault.
2. Select either the enabled, or disabled option using the Scroll (up) ▲ and Scroll (down) ▼ buttons.
3. Press the Accept ► button to confirm the changes. The Commissioning menu is displayed.

### Man Rel Mode

The manual release mode sub-menu selects either delayed, or immediate release of extinguishant.

1. From the Commissioning menu select Man Rel Mode.
2. Select either the delayed, or immediate option using the Scroll (up) ▲ and Scroll (down) ▼ buttons.
3. Press the Accept ► button to confirm the changes. The Commissioning menu is displayed.

### Zone Trigger

This sub-menu enables a short-circuit condition on the three detection zones.

1. From the Commissioning menu select Zone Trigger.
2. Select the detection zone using the Scroll (up) ▲ and Scroll (down) ▼ buttons and press the Accept ► button.
3. Select either the S/C, or Normal option using the Scroll (up) ▲ and Scroll (down) ▼ buttons.
4. Press the Accept ► button to confirm the changes. The Commissioning menu is displayed.

### Resound Fire

This sub-menu enables/disables a resound of the alarm sounders.

1. From the Commissioning menu select Resound Fire.
2. Select either the enabled, or disabled option using the Scroll (up) ▲ and Scroll (down) ▼ buttons.
3. Press the Accept ► button to confirm the changes. The Commissioning menu is displayed.

### Clean Start

This sub-menu clears the panel's memory back to its factory default settings.

1. From the Commissioning menu select Clean Start. The panel requests the confirmation code.
2. Press the Scroll (up) ▲, Accept ►, Scroll (down) ▼ and Escape ◀ buttons.
3. Press the Accept ► button to confirm the clean start. The Commissioning menu is displayed.

## Engineering

### Walk Test

To assist routine maintenance checks, a non-latching “one man walk test” facility is available. When a detector is triggered on any zone(s) in test, the alarm sounders operate for approximately one second on and eight seconds off. This cycle continues until the cause of the alarm is removed (by the test smoke clearing from the detector), at which point the detector circuit also automatically resets. As the engineer walks around the site, additional devices on the zone(s) in test can be checked with the momentary activation of the alarm sounders confirming correct operation.

Should an alarm occur on a zone that is NOT programmed for test, the alarm will be processed in the normal way. All zones that are in test will have their test temporarily suspended until the alarm(s) from the other zones are reset. At this point zone testing may resume, i.e. the alarm will operate correctly despite being in test mode.

This sub-menu allows a walk test of one, or more of the panel's three detection zones.

1. From the Engineering menu select Walk Test.
2. Select the required walk test zone (1, 2, 3, or All) using the Scroll (up) ▲ and Scroll (down) ▼ buttons.
3. Press the Accept ► button.
4. Use the Scroll (down) ▼ button to change from Normal Operation to Walk Test Mode and press the Accept ► button.
5. Repeat steps 2 to 4 to select additional zones for walk test.
6. Press the Escape ◀ button to return to the Engineering menu.

**Note:** Take the relevant zones out of test when testing is complete.

### Test Relays

This sub-menu allows the testing of one, or more of the panel's six auxiliary relay outputs: Fire, Local Fire, Extract, 1st Stage, 2nd Stage and Fault. The relay outputs' state can be set to On, Off, or Intermittent.

**Note:** If an Output Expansion Relay Board is fitted, this sub-menu also allows the testing of one, or more of the board's five relay outputs: Reset, Mode, Discharged, Hold and Abort.

1. From the Engineering menu select Test Relays.
2. Select the relay output(s) to be tested using the Scroll (up) ▲ and Scroll (down) ▼ buttons.
3. Press the Accept ► button to set the selected relay output On.
4. Or, press the Accept ► button to set the selected relay output to Intermittent.
5. Or, press the Accept ► button to set the selected relay output Off.
6. Press the Escape ◀ button to return to the Engineering menu.

### Test Sounders

This sub-menu allows the testing of 1st and 2nd stage sounder circuits by altering its state between On, Off, or Intermittent.

1. From the Engineering menu select Test Sounders.
2. Select the sounder circuit to be tested using the Scroll (up) ▲ and Scroll (down) ▼ buttons.
3. Press the Accept ► button to change the selected sounder circuit On.
4. Or, press the Accept ► button to change the selected sounder circuit to Intermittent.
5. Or, press the Accept ► button to change the selected sounder circuit Off.
6. Press the Escape ◀ button to return to the Engineering menu.

### Monitoring

This sub-menu allows a constant monitoring voltage to be temporarily applied to the sounder circuit, monitored inputs and extinguishant output.

1. From the Engineering menu select Monitoring. The LCD unit displays pulsing mode for the above circuits.  
**Note:** Pulsing mode reduces the quiescent current of the panel but may make troubleshooting difficult.
2. Press the Accept ► button and the LCD unit displays constant mode for the same circuits.
3. Perform the necessary voltage checks.
4. On completion of voltage checks, press the Escape ◀ button and the panel will automatically revert back to pulsing mode.

### Show PSU Stats

This sub-menu can assist in fault diagnosing the panel's PSU and standby battery supply.

1. From the Engineering menu select the Show PSU Stats sub-menu. The LCD unit displays the PSU and battery statistics (typical readings shown below):

```
System = 27200mV
Earth = OK (or FAIL)
PSU Comms = OK (or FAIL)
Mains = OK (or FAIL)
Batt = OK (or LOW, CRITICAL or FAULT)
Charger = OK (or FAIL)
Temp = 39°C
Battery = 26530mV
Resistance = 160mΩ
```

2. Press the Escape ◀ button to return to the Engineering menu.



### Version Numbers

This sub-menu displays the current version number of the panel's firmware and checksum data.

1. From the Engineering menu select the Version Numbers sub-menu. The LCD unit displays the release date and version of the panel's firmware (typical display shown below):



Version Numbers  
ERP xAxx  
xx/xx/xxxx

2. Press the Accept ► button and the LCD unit displays the program checksum code, site data and update count (typical display shown below):

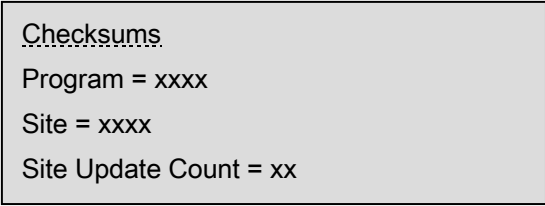

Checksums  
Program = xxxx  
Site = xxxx  
Site Update Count = xx

3. Press the Escape ◀ button to return to the Engineering menu.

## **FAULT DIAGNOSIS**

### **Overview**

When a fault occurs on the system, the EP203 panel responds by activating its internal sounder, the General Fault yellow LED flashes, any other specific yellow Fault LEDs flash and the LCD unit displays the specific fault.

The EP203 panel's fault output will also activate (provided it has NOT been disabled).

Fixing any particular fault condition will automatically clear the fault from the EP203 panel. If the EP203 panel is reset whilst faults still exist, the faults will reappear after a short duration.

**Note:** It is possible to mute the EP203 panel's internal sounder at any time by momentarily pressing the Silence Internal Sounder pushbutton.

### **Detection Zone Faults**

The three detection zone circuits are monitored for open and short-circuit faults (unless there is an alarm condition, or the zone is in test, or disabled). The following lists typical fault diagnosis for zone faults:

#### **Open-circuit, or short-circuit fault has occurred on a detection zone**

An open, or short-circuit fault on a detection zone is indicated by the following:

- Internal panel sounder activates
- General Fault yellow LED flashes
- Specific Zone Fault yellow LED flashes
- LCD unit displays the specific fault (e.g. Zone 1 O/C fault, Zone 2 S/C fault).

#### **Suggested action:**

1. Disconnect the faulty detection zone completely from the Main Control PCB and refit a 6k8 ohm end-of-line resistor at the panel terminals. If the fault condition clears this confirms there is a wiring fault.
2. Double-check and refit the circuit wiring and the end-of-line resistor. Trace the fault with consideration to the type of fault indicated at the panel and on the LCD unit.

**Note:** A common short circuit fault is a detector head badly seated in a base that is not making a true connection.

## Sounder Faults

All three alarm sounder circuits are monitored for open and short circuit faults (unless disabled, or in an alarm condition).

An open, or short-circuit fault on a sounder circuit is indicated by the following:

- Internal panel sounder activates
- General Fault yellow LED flashes
- Sounder Fault yellow LED flashes
- LCD unit displays the specific fault (e.g. Sounder circuit 1 O/C fault, Sounder circuit 2 S/C fault).

### To determine which of the panel's three sounder circuits is faulty

1. Disconnect each sounder circuit from the Main Control PCB in turn and measure the resistance between the two wires. A healthy circuit will display only the end-of-line resistor value. Any other resistance value signifies a fault.
2. If the readings from all sounder circuits are correct, take their end-of-line resistors and connect them to the sounder circuits at the panel terminals. If the fault persists, the Main Control PCB is faulty and must be replaced.
3. If a sounder circuit fault is detected, correct the fault and reconnect the sounder circuit. The sounder fault will automatically clear within 60 seconds.

**Note:** If the sounder circuit is shorted and the alarm voltage applied, the relevant sounder fuse will trip. When the fault is removed, the fuse will automatically reset.

## Power Supply Faults

**Note:** The power supply status can be viewed at Access Level 3, selecting the Engineering menu, then selecting Show PSU Stats.

When a power supply fault occurs the LCD unit displays the specific fault and the Power Supply Fault yellow LED flashes. A power supply fault arises when one, or more of the following conditions have occurred:

- The mains supply voltage is too low, or has failed completely
- The mains supply fuse (F1) has ruptured
- The battery fuse (F2) has ruptured
- The battery supply voltage is too low
- The Power Supply PCB is faulty.

The following lists typical fault diagnosis for power supply faults:

### The mains supply voltage is too low, or has failed completely

**Symptoms:** The EP203 panel is running on batteries, but NOT on mains supply. The LCD unit displays 'Mains=FAIL' and the Hazardous Voltages Present red LED on the Power Supply PCB is lit steady.

### Suggested actions:

1. Isolate the mains supply to the panel and remove the mains connector block (CONN1) from the Power Supply PCB.
2. Position the mains connector block so that the live and neutral connections can be probed. Taking all due precaution, re-apply the mains and measure the voltage.
3. Isolate the mains supply again.
4. If the voltage reading was incorrect, re-check the mains supply.  
If the voltage reading was correct, check if the mains supply fuse (F1) has ruptured. If the F1 fuse is intact and the Hazardous Voltages Present red LED on the Power Supply PCB is lit steady, then the PSU is faulty and should be replaced.

### The mains supply fuse (F1) has ruptured

**Symptoms:** The panel is running on batteries, but NOT on mains supply.

The LCD unit displays 'Mains=FAIL' and the Hazardous Voltages Present red LED on the Power Supply PCB is NOT lit.

### Suggested actions:

1. Isolate the mains supply to the panel.
2. Remove the Main Control PCB and check the mains supply fuse (F1) on the Power Supply PCB for continuity.
3. If the F1 fuse has ruptured it will be due to an excessive mains surge, or a Power Supply PCB fault. Check the components on the Power Supply PCB for signs of damage. If no damage is found, replace the F1 fuse (supplied in the accessory pack) with the correct type ensuring that the fuse clip is not damaged when re-inserting the fuse.
4. Reconnect the mains supply. If the Hazardous Voltages Present red LED is NOT lit then the Power Supply PCB is faulty and should be replaced.

### The battery fuse (F2) has ruptured

**Symptoms:** The panel is running on mains, but NOT on batteries. The LCD unit displays 'Batt=FAIL'.

### Suggested actions:

1. Isolate the mains supply to the panel and disconnect the batteries.
2. Remove the Main Control PCB and check the battery fuse (F2) on the Power Supply PCB for continuity.
3. If the F2 fuse has ruptured check the components on the Power Supply PCB and Main Control PCB for signs of damage. If no damage is found replace the F2 fuse with the correct type (supplied in the accessory pack), ensuring that the fuse clip is not damaged when re-inserting the fuse.
4. Refit the Main Control PCB and reconnect the batteries.
5. If the Supply Present green LED is lit steady, reconnect the mains supply and check that the power supply fault has cleared. If the Supply Present green LED is NOT lit, either the Power Supply PCB, or the Main Control PCB is faulty and should be replaced.
6. If the F2 fuse is intact, proceed to check the battery voltage (see below).

### The battery voltage is too low

**Symptoms:** The panel is running on mains but may, or may not, be running on batteries. The LCD unit displays 'Batt=FAIL'.

**Suggested actions:**

1. If the mains supply has failed and the battery supply has been discharged to the point where the voltage is critical, i.e. less than approx. 21V, the panel will automatically turn off to avoid damaging the batteries by allowing them to deep discharge. The panel will not restart unless fresh, fully charged batteries are connected, or the mains supply is restored.
2. If the mains supply has not failed, but the total battery voltage is less than approx. 21V, the PSU will not charge the batteries to avoid damage to the charging circuit. If the batteries can be charged, the panel will still show a power supply fault until they have sufficient charge, at which point the power supply fault will automatically be cleared. Depending on battery size and the depth of discharge, this may take several hours. If the batteries are in poor condition they must be replaced.
3. If the batteries are in good condition and all the other checks have been performed and no faults found, the Power Supply PCB is faulty and should be replaced.

**Note:** Batteries that are not connected, or connected in reverse, or with opposite polarities will also cause a power supply fault condition.

### The Supply Present green LED is NOT lit

**Symptom 1:** Both the mains supply and the standby batteries have failed. This could be because the mains supply has failed and the batteries have been exhausted.

**Suggested action:**

1. Restore the mains supply and the Supply Present green LED should come back on. However, if the batteries are discharged this will be recognized as a fault by the EP203 panel and indicated as such. See "Battery supply voltage too low" above.

**Symptom 2:** The Power Supply PCB, the Main Control PCB and/or the cable that connects them is faulty.

**Suggested action:**

1. If the mains supply is present (indicated by the Hazardous Voltages Present red LED being lit on the Power Supply PCB), check that the connector cable between the Power Supply PCB and the Main Control PCB is fully inserted at both ends. If the connector cable is fully inserted either the Power Supply PCB and/or the Main Control PCB and/or the connector cable are faulty and should be replaced.

## System Faults

System faults are unique in that they do not automatically clear when rectified.

The LCD unit displays 'System Fault' and the System Fault yellow LED flashes when one, or more of the following has occurred:

- There is a microprocessor "watchdog" fault
- The microprocessor's site memory has been corrupted
- The microprocessor's program memory has been corrupted
- The Main Control PCB is faulty

For a detailed description of what each fault is and suggested corrective action, see below:

### Watchdog fault

**Symptoms:** This type of system fault occurs when the panel's microprocessor has failed to operate correctly, e.g. due to excessive electrical interference, and the panel's "Watchdog" circuit has been unable to bring it back under control. A common symptom of this is the panel's controls locking-up.

#### Suggested action:

1. Press the panel's Reset pushbutton and, if still in Access Level 3, the Escape Access pushbutton. This should clear the fault. If the fault persists, the Main Control PCB is faulty and must be replaced.

### Site memory corruption fault

**Symptoms:** This type of system fault occurs when site specific data retained in the panel's microprocessor is found to be corrupt.

#### Suggested actions:

1. Check all the site-specific data (delays, disablements, etc.) at authorised user and engineering level.
2. If errors are found, reprogram the panel accordingly to clear the corruption.
3. If no errors are found, temporarily change some data e.g. Flooding Time. This should clear the fault. If the fault persists, the memory is damaged and the Main Control PCB must be replaced.

### Program memory corruption fault

**Symptoms:** This type of system fault occurs when the microprocessor's memory is found to be corrupt.

#### Suggested actions:

1. Reset the panel and the fault will clear. Wait for 2 minutes
2. If the fault re-occurs then the memory is damaged and the Main Control PCB must be replaced. If the fault does not re-occur, then there was a momentary disturbance during the microprocessor's self-checking routine and no further action needs to be taken.
3. If the fault persists, the Main Control PCB is faulty and must be replaced.

## GENERAL MAINTENANCE

The EP203 panel does not require any specific maintenance but the following general panel maintenance can be carried out:

1. Check the correct operation of all panel LEDs by selecting the Lamp Test function at the LCD unit (Access Level 1).
2. Check the Event Log (Access Level 2 menu) for intermittent faults.
3. Check that the correct indication is given at the EP203 panel during rotational fire alarm and extinguishant system tests.

**CAUTION: Testing of the extinguishant system should only be carried out by suitably skilled and technically competent personnel. Tests and must be performed with appropriate isolation measures in place to avoid accidental discharge of the extinguishant.**

4. If any of the panel's fuses, or PCB components become faulty, these can be removed and re-connected as previously detailed in this manual.
5. The EP203 panel uses VRLA type batteries that normally have a life expectancy of around 5 years. It is recommended that the batteries are tested in accordance with the battery manufacturers' instructions. The batteries can be removed and re-connected as previously detailed in this manual.
6. The EP203 panel can be wiped clean using a slightly damp soft cloth.

**CAUTION: Detergents, scouring materials, or solvents should not be used to clean the panel and water MUST NOT enter the panel.**

7. Periodic, planned maintenance should be carried out on the system to ensure the system is functioning correctly and limit the consequences of faults. The maintenance tests must be carried out in accordance with local regulations. Details of tests, maintenance work and false alarms are logged in the User Manual/Log Book (Document No. DFU0002031).

## APPENDICES

### APPENDIX 1 – Standby Battery Calculation Guide

The standby time of the EP203 panel after the mains has failed depends on the quiescent loading of the panel, the alarm load of the panel and the capacity of the batteries.

**Note:** LPCB approved systems must use 7Ah batteries (YUCEL Type Y7-12).

To determine the capacity of batteries required for any given standby period, the following formula should be used:

$$\text{Battery capacity (in Ah)} = 1.25 \times [(T \times A) + (SL \times RT) + H \times (P + Z + RSUs + ESUs)]$$

The multiplier 1.25 is present to account for lost capacity over the life of the batteries.

**T** = Amount of time required for the alarm

**A** = Total alarm current of panel sounders

**SL** = Total alarm current of solenoid

**RT** = Solenoid activation time

**H** = Number of hours standby required

**P** = Quiescent current of the panel = 40mA (0.040A)

**Z** = Total quiescent current of all zone devices

**RSUs** = Total quiescent current of RSUs

**ESUs** = Total quiescent current of ESUs

**Example:**

The panel has detectors consuming a total of 1mA (0.001A), five RSUs each consuming 0.01A and five ESUs each consuming 0.005A.

In alarm, there will be a solenoid load of 1A with a solenoid activation time of 5 secs (0.00139hrs), a conventional sounder load of 200mA (0.20A). The required standby time is 24 hours and the required alarm time is 0.5 hours.

---

Calculate the alarm capacity: **(T x A) + (SL x RT)**

**T** = 0.5hrs; **A** = 0.20A; **SL** = 1A; **RT** = 0.00139hrs

$$\begin{aligned} \text{The alarm capacity} &= (0.5 \times 0.20) + (1 \times 0.00139) \\ &= 0.10139 \text{ Ah} \end{aligned}$$

---

Calculate the quiescent capacity: **H x (P + Z + RSUs + ESUs)**

**H** = 24hrs; **P** = 0.040A; **Z** = 0.001A; **RSU load** = 5 x 0.01A; **ESU load** = 5 x 0.005A

$$\begin{aligned} \text{The quiescent capacity} &= 24 \times (0.040 + 0.001 + 5 \times 0.01 + 5 \times 0.005) \\ &= 2.784 \text{ Ah} \end{aligned}$$

---

$$\begin{aligned} \text{Therefore, battery capacity} &= 1.25 \times [0.10139 + 2.784] \\ &= 3.61 \text{ Ah} \end{aligned}$$



# EP203 AUTOMATIC EXTINGUISHER PANEL

## APPENDIX 2 – Extinguisher Control Panel Wiring Diagram

Notes: See Technical Specification overleaf for further details

Z1 ..... Z3 Detector Circuits 1 to 3.  
 S1A S1B S2 Sounder Circuits. Two x 1st stage; One x 2nd stage.  
 MON1 MON2 MON3 MON4 Monitored Input Circuits 1 to 6.  
 RLY1 RLY2 RLY3 RLY4 RLY5 RLY6 Relay Outputs 1 to 6.

Aux 24V Output: +/-  
 Remote Inputs: SIL-Silence Alarm; AL-Sound Alarm  
 FLT-Fault; RST-Reset.

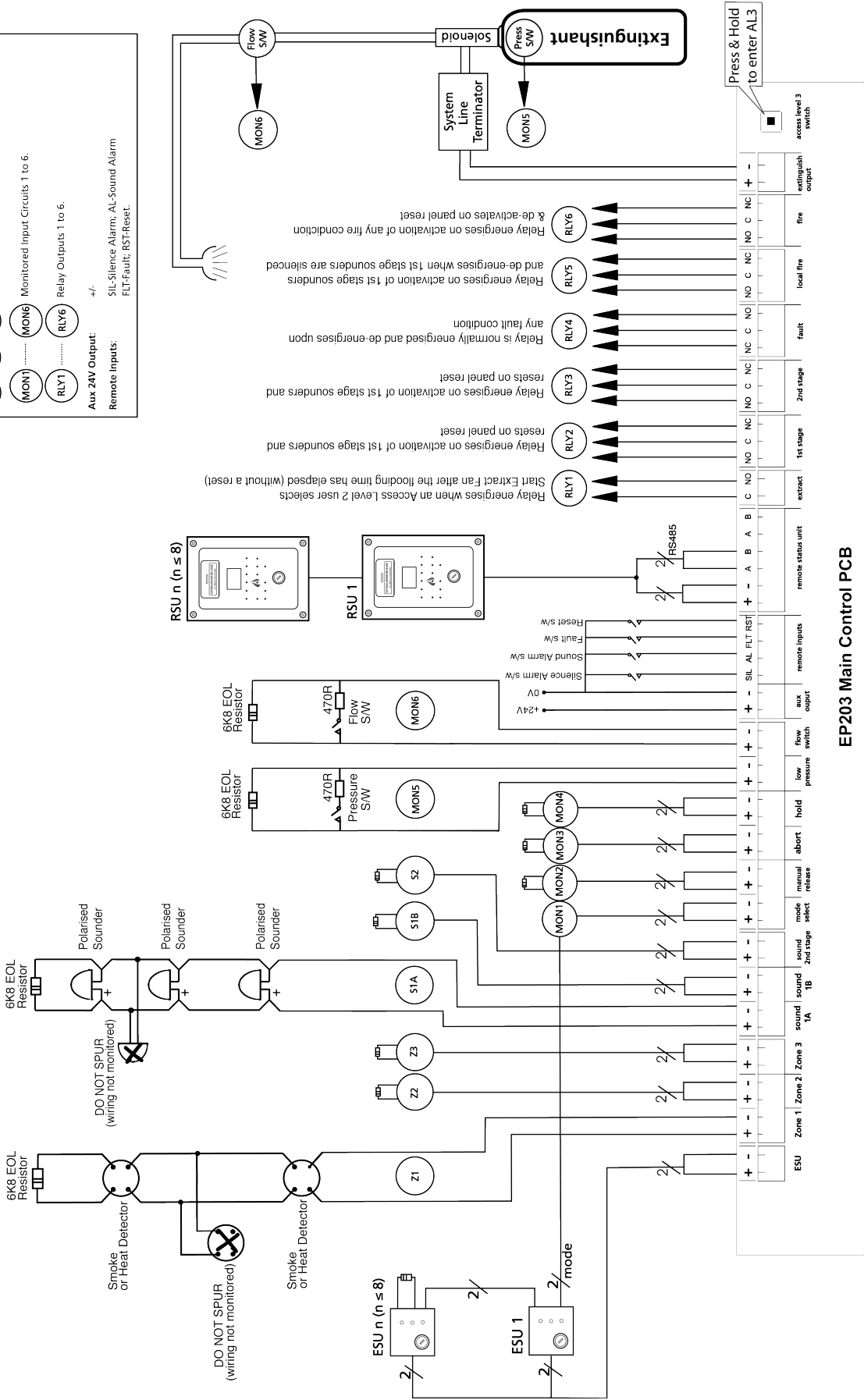

APPENDIX 3 – Extinguishing Operation Flowchart

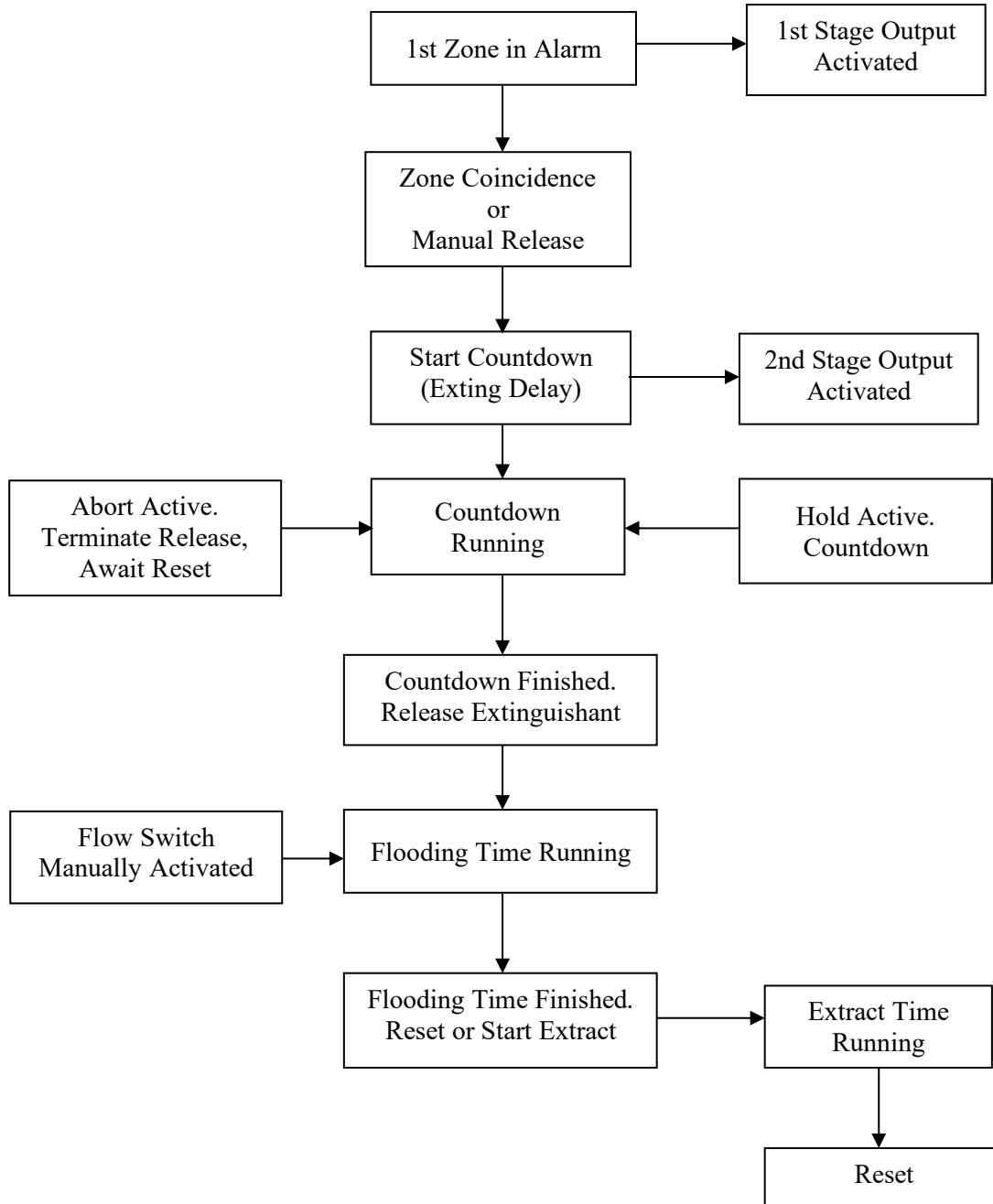

**EP203 AUTOMATIC EXTINGUISHER PANEL**

**APPENDIX 4 – Technical Specification**

<b>POWER SUPPLY</b>	
Mains supply voltage (a.c.)	230 ~, 50/60Hz. Rated current 0.8A r.m.s.
Maximum continuous output current (including charging)	3A
Battery type	YUCEL Type Y7-12 (for LPCB approved systems): 2 x 12V, 7Ah VRLA type, connected in series.
Battery characteristics	Final voltage: 21V Float charge voltage: 27.3 V ± 1% @ 20°C. Battery temp. compensation: -36mV/°K.
Output power rating	'I max a' = 800mA if DIP Switch 3 ON (UP) - Approved for EN 54-4 applications. <b>Taking a load current greater than 2A will temporarily reduce the battery charge current.</b>
	'I max b' = 1.5A cont., 3A peak current.
	'I min' = 40mA
Max. internal battery resistance 'Ri max'	1.5Ω if DIP Switch 2 OFF (DOWN). Not Approved for EN 54-4 applications.
Battery fitted DIP switch	DIP Switch 4 OFF (DOWN) – Battery fitted. Approved for EN 54-4 applications.
Maximum power output voltage 'V max'	30V
Minimum power output voltage 'V min'	20V ± 2% with mains ON
Output ripple voltage (peak-to-peak)	≤ 320mV over the full input and output range of the PSU
Mains supply/battery charger monitored for failure	YES
Batteries monitored for disconnection and failure	YES
Earth fault monitoring	YES
<b>* Definitions:</b>	
'I max. a' – is the maximum current the PSE is required to continuously supply to a fully loaded system in quiescent condition.	
'I max. b' – is the maximum current which the PSE may be required to supply to a fully loaded system during short term events.	
'I min.' – is the minimum load current that the PSE will function correctly.	
<b>DETECTOR CIRCUITS</b>	
Number of conventional detector circuits	3
Line monitored for open and short circuit faults	YES
Max. cable length per circuit	250m
Max. number of smoke/heat detectors per circuit	20
Zone quiescent detector current per circuit	2mA max. @ 19-28V
End-of-line resistor value	6K8 ohm ± 5%, 0.25W
<b>SOUNDER CIRCUITS</b>	
Number of conventional sounder circuits	3 (two x 1st stage 1A & 1B, one x 2nd stage)
Line monitored for open and short circuit faults	YES
Sounder output rating	19-28Vdc, fused @200mA per circuit
Max. sounder cable length per circuit	50m
Max. number of polarised sounders per circuit	10 @ 20mA each
End-of-line resistor value	6K8 ohm ± 5%, 0.25W
<b>MONITORED INPUTS</b>	
Number of monitored inputs	6 (Manual Release, Flow Switch, Low Pressure, Mode, Hold, Abort)
Thresholds	8k to 2k ohms (Normal); 1.8k to 200 ohms (Active); 150 to 0 ohms (Short-circuit)
End-of-line resistor value	6K8 ± 5%, 0.25W
<b>AUXILIARY OUTPUTS (RELAYS)</b>	
Number of auxiliary outputs **	6 (Fire, Local Fire, Extract, 1st Stage, 2nd Stage, Fault)
Extract time	Adjustable 1-900 seconds (1 second steps)
Relay contact rating	30Vdc, 1A max. <b>Note:</b> DO NOT switch mains voltages using these outputs.
<b>** Note:</b> Five additional relay outputs (Reset, Mode, Discharged, Hold, Abort) are available on the EP212 Output Expansion Relay Board.	
<b>REMOTE INPUTS &amp; AUX OUTPUT</b>	
Number of remote inputs	4 (SIL, AL, FLT, RST). Total wiring length for each circuit < 30 metres.
Aux output (power)	19-28V, 100mA electronic fuse. Total wiring length < 30 metres.
<b>EXTINGUISHANT RELEASE OUTPUTS</b>	
Extinguishant release output	19-28Vdc, rated at 1A for 5 mins.
Extinguishant release time delay	Adjustable 0-60 seconds (1 second steps)
Extinguishant release duration	Adjustable 1-300 seconds (1 second steps)
Extinguishant release flooding time	Adjustable 60-1740 seconds (1 second steps)
Extinguishant output end-of-line	System Line Terminator (Part No. EP214)
<b>FUSES Compliant with IEC (EN 60127 Pt2)</b>	
Mains supply fuse (F1)	T 2A H 230 V, 20 mm ceramic (T = Time Delay; H = High Breaking Capacity)
Battery fuse (F2)	7.5A MINI® automotive blade fuse
Auxiliary output fuse	100mA electronic
Sounder circuit fuse	200mA per circuit

## EP203 AUTOMATIC EXTINGUISHER PANEL

### APPENDIX 4 – Technical Specification (continued)

<b>CONTROLS &amp; INDICATORS</b>	
Status Display Unit	128 x 64 pixel graphic LCD unit, two-colour backlight
Access Level 1 menu	<ul style="list-style-type: none"> <li>• Display Faults; Display Dis/mnt; Zones in Test; Lamp Test; Alarm Counter</li> </ul>
Access Level 2 menu	<ul style="list-style-type: none"> <li>• Display Faults</li> <li>• Display Dis/mnt</li> <li>• Zones in Test</li> <li>• Lamp Test</li> <li>• Alarm Counter</li> <li>• Set Time/Date</li> <li>• Event Log</li> <li>• Disp Contrast</li> <li>• Disablements</li> </ul>
Access Level 3 menu	<ul style="list-style-type: none"> <li>• Display Faults</li> <li>• Display Dis/mnt</li> <li>• Zones in Test</li> <li>• Display RSUs</li> <li>• Disablements</li> <li>• Commissioning</li> <li>• Engineering</li> </ul>
Controls (2 x keyswitches)	<ul style="list-style-type: none"> <li>• accessed.</li> <li>• manual only, or manual &amp; automatic.</li> </ul>
Controls (pushbuttons)	<ul style="list-style-type: none"> <li>• menu, silence internal sounder, control panel reset, silence/resound sounders.</li> <li>• scroll (up), scroll (down), escape, accept.</li> <li>• Extinguisher Release (housed in yellow casing).</li> </ul>
Indicators (LEDs)	<ul style="list-style-type: none"> <li>• general fire, fire zones (x3).</li> <li>• general disablement, zone fault/disable/test (x3).</li> <li>• hold, first stage output, release imminent (x2), extinguishant released, abort.</li> <li>• disablements: extinguishant release, manual release, first stage output, second stage output, sounder.</li> <li>• manual only, manual &amp; automatic, supply present, power supply fault, accessed, test, general fault, system fault, delays, sounder fault, flooding zone fault, low pressure fault.</li> </ul>
Internal control (pushbutton)	Access level 3 switch (located on Main Control PCB)
<b>DIMENSIONS &amp; WEIGHT</b>	
Dimensions of back box	439mm(w) x 276mm(h) x 70mm(d) approx. (metal)
Dimensions of lid	467mm(w) x 293mm(h) x 29mm(d) approx. (plastic)
Weight (without batteries)	4.2kg
<b>OPERATING CONDITIONS</b>	
<p>The control panel enclosure has an IP30 rating and is designed for indoor use only. The components are selected to operate within their specification when the environmental conditions outside the enclosure comply with class 3k5 of IEC 721-3-3 : 1978.</p> <p>Temperature Range: -5 to +40°C. Maximum relative humidity: 95%.</p>	

<b>OPTIONAL OUTPUT EXPANSION RELAY BOARD - Part No. EP212</b>	
Number of volt-free relay outputs	5 (Reset, Mode Switch, Discharged, Hold, Abort)
<b>OPTIONAL REMOTE STATUS UNIT (RSU) - Part No. EP210S (surface) / EP210F (flush)</b>	
RSU connection	2-wire RS485 + 2-wire power (24V). Total wiring length < 30 metres.
RSU power output	19-28Vdc, 200mA electronic fuse
Max. number of RSUs	8
Number of monitored inputs	3 (Abort, Hold, Mode)
Status Display Unit	128 x 64 pixel graphic LCD unit, two-colour backlight
Dimension of surface-mount enclosure	160mm(w) x 240mm(h) x 51mm(d) approx. (metal)
Dimension of flush-mount enclosure	175mm(w) x 250mm(h) x 53mm(d) approx. (metal)
<b>OPTIONAL ECONOMY STATUS UNIT (ESU) - Part No. EP211</b>	
ESU connection	2-wire power (24V) + 2-wire mode select. Total wiring length < 30 metres.
ESU power	100mA electronic fuse
Maximum number of ESUs	8
Dimension of flush-mount enclosure	87mm(w) x 87mm(h) x 35mm(d) approx. (plastic)
<b>CERTIFICATES (Certificates and DOPs are available for download on C-TEC's website) <a href="http://www.c-tec.com">www.c-tec.com</a></b>	
Tested to	EN 12094-1:2003; EN 54-2:1997 + A1:2006 +A2:2007; EN 54-4:1997 + A1:2002 + A2:2006
LPCB Certificate Number	176c
LPCB Reference Number	176c/01 (EP203)
CPR Certificate Number	2831-CPR-F4090
DOP Number	DOP0000024
UKCA Certificate Number	0832-UKCA-CPR-F1111 (EP203)